



Brother Color Laser Printer

HL-4000CN

USER'S GUIDE

Please read this manual thoroughly before using the printer. You can print or view this manual from the CD-ROM at any time. Please keep the CD-ROM in a convenient place for quick and easy reference at all times.

The Brother Solutions Center (<http://solutions.brother.com>) is your one stop resource for all your printer needs. Download the latest drivers and utilities for your printers, read the FAQs and troubleshooting tips or learn about special printing solutions in the 'Solutions' and 'Customer Education' sections.



**Brother Laser Printer
HL-4000CN Series
User's Guide**

(For USA & CANADA Only)

IMPORTANT INFORMATION: For technical and operational assistance, you must call the country where you purchased the printer. Calls must be made *from within* that country.

In USA: 1-800-276-7746

In Canada: 1-800-853-6660
514-685-6464 (In Montreal)

If you have comments or suggestions, please write us at:

In USA: Printer Customer Support
Brother International Corporation
15 Musick
Irvine, CA 92618

In Canada: Brother International Corporation (Canada), Ltd.
- Marketing Dept.
1, rue Hôtel de Ville
Dollard-des-Ormeaux, PQ, Canada H9B 3H6

FAX-BACK SYSTEM

Brother Customer Service has installed an easy to use fax-back system so you can get instant answers to common technical questions and product information for all Brother products. This is available 24 hours a day, 7 days a week. You can use the system to send the information to any fax machine, not just the one from which you are calling.

Call and follow the voice prompts to receive faxed instructions on how to use the system and your index of fax-back subjects.

In USA: 1-800-521-2846

In Canada: 1-800-685-5381
1-514-685-5381 (In Montreal)

DEALERS/SERVICE CENTERS (USA Only)

For the name of an authorized dealer or service center, call 1-800-284-4357.

SERVICE CENTERS (Canada Only)

For service center addresses in Canada, call 1-800-853-6660

INTERNET ADDRESSES

Brother Global Web Site: <http://www.brother.com>

For Frequently Asked Questions (FAQs), Product Support and Technical Questions, and Driver Updates:
<http://solutions.brother.com>

(USA Only) For Brother Accessories & Supplies: <http://www.brothermall.com>

Trademarks

Brother is a registered trademark of Brother Industries, Ltd.

Apple and LaserWriter are registered trademarks, and TrueType is a trademark of Apple Computer, Inc. Centronics is a trademark of Genicom Corporation.

Hewlett-Packard, HP, PCL 5e, PCL 6 and PCL are registered trademarks of Hewlett-Packard Company.

PostScript is a registered trademark of Adobe Systems Incorporated.

This printer contains UFST and Micro Type from Agfa Division.

PANTONE Colors generated by the HL-4000CN are four- and/or three-color process simulations and may not match PANTONE-identified solid color standards. Use current PANTONE Color Reference Manuals for accurate color.

PANTONE Color simulations are only obtainable on this product when driven by qualified Pantone-licensed software packages. Contact Pantone Inc. for a current list of qualified licensees.

Trademarks noted herein are the property of Brother Industries, Ltd. PANTONE® and other Pantone, Inc. trademarks are the property of Pantone, Inc. ©Pantone, Inc., 1988

ENERGY STAR is a U.S. registered mark.

All other brand and product names mentioned in this user's guide are registered trademarks or trademarks of respective companies.

Compilation and Publication

Under the supervision of Brother Industries Ltd., this manual has been compiled and published, covering the latest product descriptions and specifications.

The contents of this manual and the specifications of this product are subject to change without notice.

Brother reserves the right to make changes without notice in the specifications and materials contained herein and shall not be responsible for any damages (including consequential) caused by reliance on the materials presented, including but not limited to typographical and other errors relating to the publication.

©2002 Brother Industries Ltd.

Shipment of the Printer

If for any reason you must ship your Printer, carefully package the Printer to avoid any damage during transit. It is recommended that you save and use the original packaging. The Printer should also be adequately insured with the carrier.

REGULATIONS

Electronic Emission Notices

Federal Communications Commission (FCC) Declaration of Conformity (For U.S.A. Only)

Responsible Party: Brother International Corporation
100 Somerset Corporate Boulevard
Bridgewater, NJ 08807-0911, USA
TEL: (908) 704-1700

declares, that the products

Product Name: Brother Laser Printer HL-4000CN
Model Number: HL-4000CN
Product Options: ALL

complies with Part 15 of the FCC Rules. Operation is subject to the following two conditions: (1) This device may not cause harmful interference, and (2) this device must accept any interference received, including interference that may cause undesired operation.

This equipment has been tested and found to comply with the limits for a Class B digital device, pursuant to Part 15 of the FCC Rules. These limits are designed to provide reasonable protection against harmful interference in a residential installation. This equipment generates, uses, and can radiate radio frequency energy and, if not installed and used in accordance with the instructions, may cause harmful interference to radio communications. However, there is no guarantee that interference will not occur in a particular installation. If this equipment does cause harmful interference to radio or television reception, which can be determined by turning the equipment off and on, the user is encouraged to try to correct the interference by one or more of the following measures:

- Adjust relocate the receiving antenna.
- Increase the distance between the equipment and the receiver.
- Connect the equipment to a socket on a circuit different from that which the receiver is already connected.
- Consult the dealer or an experienced radio/TV technician for help.

Important

A shielded interface cable should be used in order to ensure compliance with the limits for a Class B digital device.

Changes or modifications not expressly approved by Brother Industries, Ltd. could void the user's authority to operate the equipment.

Industry Canada Compliance Statement (For Canada Only)

This Class B digital apparatus complies with Canadian ICES-003.
Cet appareil numérique de la classe B est conforme à la norme NMB-003 du Canada.



“EC” Declaration of Conformity

Manufacturer

Brother Industries Ltd.,
15-1, Naeshiro-cho, Mizuho-ku,
Nagoya 467-8561, Japan

Herewith declare that:

Products description : Laser Printer
Product Name : HL-4000CN

is in conformity with provisions of the Directives applied : Low Voltage Directive 73/23/EEC (as amended by 93/68/EEC) and the Electromagnetic Compatibility Directive 89/336/EEC (as amended by 91/263/EEC and 92/31/EEC and 93/68/EEC).

Standards applied :

Harmonized :

Safety : EN60950:1992 + A1:1993 + A2:1993 + A3:1995 + A4:1997 + A11:1997

EMC : EN55022:1998 Class B
EN55024:1998
EN61000-3-2:1995 + A1:1998 + A2:1998
EN61000-3-3:1995

Year in which CE marking was First affixed : 2001

Issued by : Brother Industries, Ltd.

Date : 19 November, 2001

Place : Nagoya, Japan

Signature :

Kazuhiro Dejima
Manager
Quality Audit Group
Quality Management Dept.
Information & Document Company

International ENERGY STAR® Compliance Statement

ENERGY STAR® is a U.S. registered mark.

The purpose of the International ENERGY STAR® Program is to promote the development and popularization of energy-efficient office equipments.

As an ENERGY STAR® Partner, Brother Industries, Ltd. has determined that this product meets the ENERGY STAR® guidelines for energy efficiency.



Laser Notices

Laser Safety (120 V Model Only)

This printer is certified as a Class I laser product under the U.S. Department of Health and Human Services (DHHS) Radiation Performance Standard according to the Radiation Control for Health and Safety Act of 1968. This means that the printer does not produce hazardous laser radiation.

Since radiation emitted inside the printer is completely confined within protective housings and external covers, the laser beam cannot escape from the machine during any phase of user operation. However, the machine contains 5-milliwatt, 700-800 nanometer wavelength, GaAlAs laser diodes. Direct (or indirect reflected) eye contact with the laser beam might cause serious eye damage. Safety precautions and interlock mechanisms have been designed to prevent any possible laser beam exposure to the operator.

FDA Regulations (120 V Model Only)

U.S. Food and Drug Administration (FDA) has implemented regulations for laser products manufactured on and after August 2, 1976. Compliance is mandatory for products marketed in the United States. The label shown on the back of the printer indicates compliance with the FDA regulations and must be attached to laser products marketed in the United States.

<p>MANUFACTURED: BROTHER INDUSTRIES, LTD. 15-1 Naeshiro-cho, Mizuho-ku, Nagoya, 467-8561 Japan This product complies with FDA radiation performance standards, 21 CFR Subchapter J.</p>

Caution: Use of controls, adjustments or the performance of procedures other than those specified in this manual may result in hazardous radiation exposure.

IEC 60825 Specification (220 - 240 V Model Only)

This printer is a Class 1 laser product as defined in IEC 60825 specifications. The label shown below is attached in countries where required.



This printer has a Class 3B Laser Diode that emits invisible laser radiation in the Scanner Unit. The Scanner Unit should not be opened under any circumstances.

Caution: Use of controls, adjustments or the performance of procedures other than those specified in this manual may result in hazardous radiation exposure.

For Finland and Sweden

LUOKAN 1 LASERLAITE KLASS 1 LASER APPARAT

Varoitus! Laitteen käyttäminen muulla kuin tässä käyttöohjeessa mainitulla tavalla saattaa altistaa käyttäjän turvallisuusluokan 1 ylittävälle näkymättömälle lasersäteilylle.

Varning – Om apparaten används på **annat** sätt än i denna Bruksanvisning specificerats, kan användaren utsättas för osynlig laserstrålning, som överskrider gränsen för laserklass 1.

Internal laser radiation

Max. Radiation Power	10 mW
Wave Length	770 nm-808 nm
Laser Class	Class IIIb (Accordance with 21 CFR Part 1040.10) Class 3B (Accordance with IEC60825)

Safety Information

IMPORTANT - For Your Safety

To ensure safe operation the three-pin plug supplied must be inserted only into a standard three-pin power point socket which is properly earthed through the normal household wiring.

Extension cords should not be used with the equipment. If it is essential that an extension cord has to be used, it must be a three-pin plug type and correctly wired to provide proper earthing. Incorrectly wired extension cords may cause personal injury and equipment damage.

The fact that the equipment operates satisfactorily does not imply that the power is earthed and that the installation is completely safe. For your safety, if in any doubt about the effective earthing of the power, consult a qualified electrician.

Caution

Use of controls or adjustment or performance of procedures other than those specified in this manual might result in hazardous radiation exposure.

Disconnect device

This printer must be installed near a power socket that is easily accessible. In case of emergencies, you must disconnect the power cord from the power socket to shut off the power completely.

Caution for batteries

Do not replace the battery. There is a danger of explosion if the battery is incorrectly replaced. Do not disassemble, recharge or dispose of in a fire. Used batteries should be disposed of according to local regulations.

Opmerking / Oplaadbare Batterij Recycle Informatie (For Netherlands Only)

Bij dit product zijn batterijen geleverd. Wanneer deze leeg zijn, moet u ze niet weggooien maar inleveren als Klein Chemisch Afval.



Geräuschemission / Acoustic Noise Emission (For Germany Only)

L_{pa} < 70 dB (A) DIN 45635-19-01-KL2

IT power system (For Norway Only)

This product is also designed for IT power system with Phase to phase voltage 230V.

LAN Connection

Caution: Connect this production to a LAN connection which is not subjected to overvoltages.

Wiring Information (For U.K. only)

Important

If the mains plug supplied with this printer is not suitable for your socket outlet, remove the plug from the mains cord and fit an appropriate three pin plug. If the replacement plug is intended to take a fuse then fit the same rating fuse as the original.

If a moulded plug is severed from the mains cord then it should be destroyed because a plug with cut wires is dangerous if engaged in a live socket outlet. Do not leave it where a child might find it!

In the event of replacing the plug fuse, fit a fuse approved by ASTA to BS1362 with the same rating as the original fuse.

Always replace the fuse cover. Never use a plug with the cover removed.

WARNING - THIS PRINTER MUST BE PROPERLY EARTHED.

The wires in the mains cord are colored in accordance with the following code:

Green and yellow:	Earth
Blue:	Neutral
Brown:	Live

The colors of the wires in the main lead of this printer may not correspond with the colored markings identifying the terminals in your plug.

If you need to fit a different plug, proceed as follows.

Remove a length of the cord outer sheath, taking care not to damage the colored insulation of the wires inside.

Cut each of the three wires to the appropriate length. If the construction of the plug permits, leave the green and yellow wire longer than the others so that, in the event that the cord is pulled out of the plug, the green and yellow wire will be the last to disconnect.

Remove a short section of the colored insulation to expose the wires.

The wire which is colored green and yellow must be connected to the terminal in the plug which is marked with the letter "E" or by the safety earth symbol \perp or colored green or green and yellow.

The wire which is colored blue must be connected to the terminal which is marked with the letter "N" or colored black or blue.

The wire which is colored brown must be connected to the terminal which is marked with the letter "L" or colored red or brown.

The outer sheath of the cord must be secured inside the plug. The colored wires should not hang out of the plug.

Introduction

Thank you for purchasing the HL-4000CN. This guide contains important information about the printer operation and precautions to be followed. To help you use it efficiently, please read this guide before using your new printer. Furthermore, after you read the guide, store it in a safe place. It will be useful in case you forget how to perform operations or if a problem occurs with the printer.

This guide is written for users who are familiar with the personal computers, operating systems, and software compatible with this printer. For operational procedures and information regarding these items, refer to the documentation provided with the various hardware and software that you are using.

Brother Industries Ltd.

Table of Contents

REGULATIONS.....	iv
Introduction.....	xi
Table of Contents.....	xii
How to Use This Guide.....	xvii
Conventions.....	xvii
❖ Glossary	xvii
❖ Symbol	xviii
Safety Precautions	xix
CHAPTER 1 PRINTER SYSTEM SETTINGS	1-1
1.1 Adjusting Color Registration.....	1-1
❖ Printing the Color Registration Chart.....	1-1
❖ Determining values	1-2
❖ Entering Values.....	1-2
1.2 Configuring the Printer on a Network.....	1-4
1.2.1 Setting an IP Address.....	1-4
❖ Set the IP address acquisition method to 'Panel'	1-4
❖ Setting the IP Address	1-6
❖ Setting the Subnet Mask.....	1-7
❖ Setting the Gateway Address	1-8
1.2.2 Setting Protocols.....	1-9
❖ Changing Protocol Settings	1-10
1.2.3 Confirming Settings.....	1-12
CHAPTER 2 INSTALLING THE PRINTER DRIVER.....	2-1
2.1 Installing the Printer Driver (Windows)	2-1
2.1.1 Installing the Printer Driver	2-1
2.1.2 Upgrading the Printer Driver	2-1
2.2 Installing the Printer Driver (Macintosh)	2-3
2.2.1 Installing the Printer Driver	2-3
2.2.2 Upgrading the Printer Driver	2-3
CHAPTER 3 BASIC PRINTER OPERATION	3-1
3.1 Printer Part Names and Functions	3-1
❖ Front View	3-1
❖ Rear View	3-2
❖ Internal View.....	3-3
3.2 Turning the Printer On and Off.....	3-4
3.2.1 Turn the Printer On.....	3-4
3.2.2 Turn the Printer Off	3-5

3.3	Printing from a Computer	3-6
3.3.1	In Windows.....	3-6
	❖ Printing from a program.....	3-6
	❖ Changing default printing functions.....	3-7
3.3.2	With a Macintosh Computer.....	3-9
3.4	Using Help	3-10
3.4.1	Referring to Windows Help.....	3-11
	❖ To refer to Help, open the Properties dialog box and select the tab that contains the item in question.	3-11
3.4.2	Referring to Balloon Help on Macintosh.....	3-12
3.5	Cancel Printing	3-13
3.5.1	Cancel Printing on the Computer	3-13
	❖ In Windows	3-13
	❖ On a Macintosh Computer	3-14
3.5.2	Cancel Printing from the Control Panel.....	3-15
3.6	Changing the Configuration for Options	3-16
3.6.1	In Windows.....	3-17
3.6.2	On a Macintosh computer	3-18
3.7	Printing on Envelopes, Transparency Sheets, and Custom-size (Long) Paper.....	3-19
3.7.1	Printing on Envelopes.....	3-19
	❖ Printer Driver Settings (for envelopes)	3-20
3.7.2	Printing on Transparency Sheets	3-22
	❖ Printer Driver Settings (for transparency sheets)	3-23
3.7.3	Printing Custom-size Paper	3-24
	❖ Setting a User Defined Size	3-24
	❖ How to Print.....	3-25
	❖ Printer Driver Settings (for Custom-size (Long) Paper)	3-26
3.8	Duplex Printing.....	3-27
	❖ Types of Duplex Printing.....	3-27
3.8.1	Duplex Printing	3-28
	❖ Printer Driver Settings (for duplex printing on plain paper)	3-28
	❖ Printer Driver Settings (for printing the back side of specialty paper).....	3-29
CHAPTER 4 LOADING PAPER AND USABLE PAPER TYPES.....		4-1
4.1	Suitable and Unsuitable Paper Types.....	4-1
4.1.1	Suitable Paper Types.....	4-1
	❖ Suitable Basis Weight	4-1
	❖ Recommended Paper.....	4-2
	❖ Special paper.....	4-2
	❖ Paper Trays, Types, and Sizes.....	4-4
	❖ Duplex Printing Paper Types and Sizes	4-5
4.1.2	Unsuitable Paper Types	4-6
4.1.3	Storing Paper	4-7
4.2	Loading Paper.....	4-8
4.2.1	Load Paper in the Paper Tray.....	4-8
4.2.2	Load A5 Paper in the Paper Tray/Changing the Paper Size from A5.....	4-12
	❖ Loading A5 Paper	4-12
	❖ Changing the Paper Size from A5.....	4-15
4.2.3	Load Paper into the Multi-purpose Tray.....	4-19

CHAPTER 5 CONTROL PANEL 5-1

5.1 Control Panel Functionality..... 5-1

- 5.1.1 LED Indicators 5-2
- 5.1.2 Display 5-3
 - ❖ Print screen..... 5-3
 - ❖ Menu screen 5-3
- 5.1.3 Buttons 5-4

5.2 Basic Menu Operation..... 5-5

- 5.2.1 Menu Structure and Basic Operations 5-5
 - ❖ Resetting the printer settings 5-5
- 5.2.2 What to do if you make a Mistake? 5-6

5.3 List of Menu Items..... 5-7

- 5.3.1 System Settings 5-7
 - ❖ Power Save Time 5-7
 - ❖ Error Alarm 5-8
 - ❖ Job Timeout..... 5-9
 - ❖ Panel Language 5-9
 - ❖ Auto Log Print 5-9
 - ❖ ID Print..... 5-9
 - ❖ Text Print 5-10
- 5.3.2 Maintenance Mode 5-10
 - ❖ Init NVM..... 5-10
 - ❖ Security 5-11
 - ❖ Basis Weight 5-11
 - ❖ ColorRegiCorrect 5-11
- 5.3.3 Parallel..... 5-12
 - ❖ ECP 5-12
- 5.3.4 Report/List..... 5-12
 - ❖ Printer Settings 5-12
 - ❖ Panel Settings 5-12
 - ❖ PCL6 Font List 5-12
 - ❖ Log Print 5-13
- 5.3.5 Network..... 5-13
 - ❖ Ethernet 5-13
 - ❖ TCP/IP..... 5-13
 - ❖ IPX Frame Type..... 5-14
 - ❖ Protocol 5-15
 - ❖ IP Filter 5-16
 - ❖ Init NVM..... 5-16
- 5.3.6 USB 5-17
 - ❖ Adobe Protocol 5-17

CHAPTER 6 DEALING WITH PROBLEMS..... 6-1

6.1 Troubleshooting 6-1

6.2 Power Problems 6-2

6.3 Printing Problems 6-3

- 6.3.1 Indicators are on, flashing, or off..... 6-3
- 6.3.2 Cannot Print in Windows..... 6-5
- 6.3.3 Cannot Print from a Macintosh Computer..... 6-6

6.4	Print Quality Problems	6-7
6.4.1	Blank or Completely Black Pages are Output	6-7
6.4.2	Faded or Dirty Printouts, White Areas (drop-outs), Creases, Blurs	6-8
6.4.3	Unsatisfactory Printing	6-12
6.5	Paper Feed Problems.....	6-13
6.6	Others Problems	6-15
6.6.1	Network Problems	6-15
6.6.2	Other Problems.....	6-16
6.7	What to Do When an Error Message Appears	6-17
6.8	The Alarm Indicator is On or Flashing	6-22
6.8.1	The Alarm Lamp is On.....	6-22
6.8.2	The Alarm Lamp is Flashing	6-22
6.9	Forcing the Printer to Print Remaining Data (When Printing is Halted).....	6-23
6.10	Cleaning the Density Sensor	6-24
CHAPTER 7 PAPER JAMS		7-1
7.1	Clearing Paper Jams	7-1
7.2	Paper Jams in the Multi-purpose Tray	7-3
7.3	Paper Jams in the Paper Tray	7-4
7.4	Paper Jams Between the Print Head Cartridge and the Fuser Cartridge	7-6
	❖ Paper jams around the print head cartridge:.....	7-6
	❖ Paper jams around the fuser cartridge:	7-8
	❖ Paper longer than 355.6 mm (14 in.) jams	7-9
7.5	Paper Jams in the Paper Rotator	7-10
7.6	Paper Jams in the 2 Tray Module.....	7-11
CHAPTER 8 ROUTINE MAINTENANCE AND CONSUMABLE REPLACEMENT.....		8-1
8.1	Replacing the Toner Cartridges	8-1
8.1.1	Toner Cartridge Handling Precautions	8-1
	❖ Handling Precautions	8-1
	❖ Storage Precautions	8-2
8.1.2	Replacing the Toner Cartridges	8-2
8.2	Replacing the Print Head Cartridge	8-5
8.2.1	Print Head Cartridge Handling Precautions	8-5
	❖ Handling Precautions	8-5
	❖ Storage Precautions	8-6
8.2.2	Replacing the Print Head Cartridge.....	8-6

8.3	Replacing the Transfer Roll Cartridge	8-11
8.3.1	Transfer Roll Cartridge Handling Precautions	8-12
	❖ Handling Precautions	8-12
8.3.2	Replacing the Transfer Roll Cartridge.....	8-13
8.4	Printing Reports and Lists	8-15
8.4.1	Confirming Printer Configuration and Network Settings	8-16
8.4.2	Checking the Print Log.....	8-17
8.5	Confirming Printer Status from Your Computer	8-18
8.5.1	Checking Status and Remaining Amounts of Consumables using a Web Browser	8-18
8.6	Cleaning the Printer	8-19
	❖ Cleaning Precautions.....	8-19
	❖ Cleaning the outside of the printer	8-19
8.7	Transporting the Printer	8-20
8.8	Storing the Printer	8-25
APPENDIXES		A-1
A.1	Introduction to the Optional and Consumable Items	A-1
A.1.1	Options	A-1
	❖ Hard Disk	A-1
	❖ 2 Tray Module.....	A-1
	❖ Memory Expansion Card	A-1
A.1.2	Consumable Items	A-2
	❖ Toner Cartridges	A-2
	❖ Print Head Cartridge	A-2
	❖ Transfer Roll Cartridge	A-2
A.2	Getting Product Support Information	A-3
A.3	General Specifications	A-4
A.3.1	Printer Specifications.....	A-4
A.3.2	Network Specifications.....	A-7
	❖ Common Specifications	A-7
	❖ TCP/IP Specifications	A-7
	❖ NetBIOS Specifications	A-7
	❖ NetWare Specifications.....	A-7
	❖ AppleTalk Specifications	A-7
A.3.3	Printable Area	A-8
A.4	Life Span of Consumable Items	A-9
	❖ Life span of consumables (in printable pages).....	A-9
A.5	Adding the Expansion Memory	A-10
INDEX		I-1

How to Use This Guide

Conventions

The following terms and symbols are used in the present guide:

❖ Glossary

☞ Look

Alerts you to an important operating procedure that should be performed with care. Make sure that you read these items.

⇒ Note

Notes provide you with useful information.

📖 See

References indicate related information that may be useful.

“ ” Indicates that the reference is in this guide.

“ ” Indicates that the reference is in another guide.

❖ **Symbol**

Symbol	Meaning
Key	Indicates a key on the keyboard of your computer. Example: Press the Enter key
[]	Indicates a window, dialog box, or tab element or button displayed on the computer screen. Also indicates a menu or value displayed on the control panel. Example: Click [OK] in the [Properties] dialog box. Set [Enabled] on the control panel.
“ ”	Indicates a message displayed on the printer's control panel. This may also emphasize a part name or important information to be entered. Example: “Ready to Print” appears. Enter “0.0.0.0”
< >	Indicates a control panel button. Example: Press the < ▲ > button.
+	Indicates that you need to press 2 keys or control panel buttons at the same time. Example: Press the < ▲ > + < ▼ > buttons.

Safety Precautions

To ensure the safe operation of your printer, make sure that you read this section thoroughly before use.

This section describes the conventions used in the guide.

⚠ WARNING “Warning” alerts you to situations that could result in serious injury or death.

⚠ CAUTION “Caution” alerts you to situations that could cause injury or material damage.

△ This symbol alerts you to procedures that require close attention. Make sure that you read and follow the instructions carefully.



High temperature



Flammable



Electrical shock



Finger injury

⊘ This symbol alerts you to prohibited procedures. Make sure that you read the instructions carefully.



Prohibited



No naked flame



Do not dismantle



Do not touch

● This symbol alerts you to procedures that need to be performed. Make sure that you perform the procedure after reading the instructions carefully.



Hint



Remove the plug



Ground the earth

Installing and Relocating your Printer

⚠ CAUTION



Do not place the printer in a hot, humid, dusty, or poorly ventilated environment. Prolonged exposure to such adverse conditions can cause fire or electric shocks.



Do not place the printer near heaters or volatile, flammable, or combustible materials, such as curtains.



Place the printer on a level, sturdy surface that can withstand the printer's weight. Failure to do so could cause the printer to fall, resulting in injuries.



To prevent injuries, this printer should be lifted by at least two people.



To lift the printer, face the front of the printer and grip the recessed areas at the bottom left and right with both hands. Never try to lift the printer by gripping any other areas. Lifting the printer by gripping other areas can cause the printer to fall, resulting in injuries.

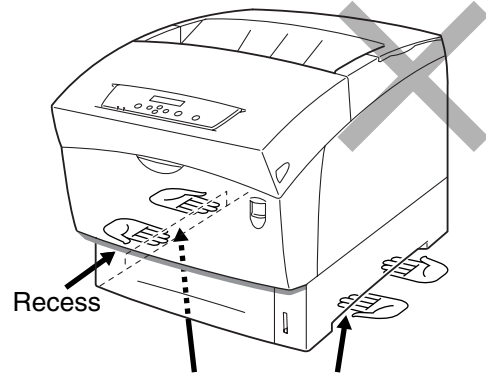
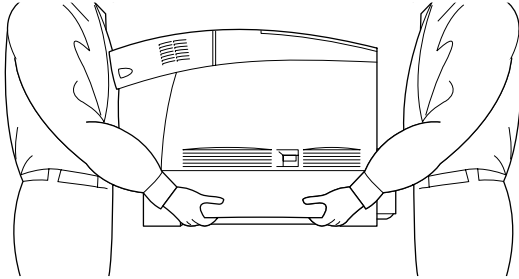

If you hold the printer by the front cover, left or right sides, there is a danger of the printer falling.



When lifting the printer, get a firm footing and bend your knees to avoid possible injuries to your back.

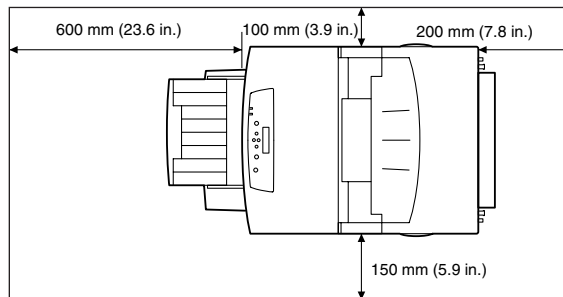

The printer has ventilation grills on the side and at the rear. Ensure that the printer is installed no less than 150 mm (5.9 in.) from the wall on the right, 100 mm (3.9 in.) from the wall on the left, and 200 mm (7.8 in.) from the wall at the back. A poorly ventilated printer can cause excessive internal heat to build up and result in fire.

The diagram below shows the minimum clearances required for normal operation, consumables replacement, and maintenance ensuring that your printer operates at peak performance.



When moving the printer, be sure to unplug the power cord from the socket. Moving the printer with the power cord connected can damage the power cord, which could result in a fire or electric shocks.



When moving the printer, do not tilt it at more than the angles shown in the diagram below.

If tilted excessively, the printer may fall, resulting in injuries.

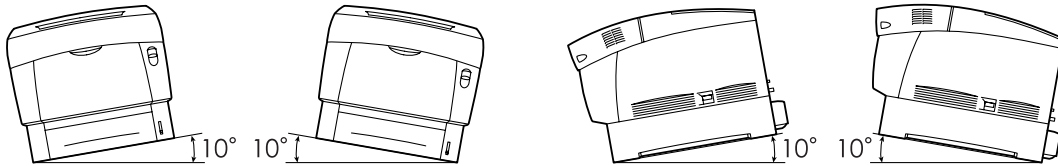

After installing the optional tray module, lock down the brakes of the casters at the front of the tray module. Failure to lock down the brakes can cause the printer to move unexpectedly, resulting in injuries.

Operating Environment

- Use the printer in a place that meets the following requirements:
Ambient temperature range of 10 to 32°C (50.0 to 89.6°F), relative humidity of 15 to 85% (no condensation)
When using the printer at an ambient temperature of 32°C (89.6°F), the relative humidity should not exceed 65%. When the relative humidity reaches 85%, the ambient temperature should not exceed 28°C (82.4°F).

⇒ **Note**

Do not place the printer in a room where there are sudden fluctuations in temperature and do not move the printer from a cold place to a warm humid place. If you do, condensation may occur inside the printer and deteriorate print quality.

- Do not place the printer in direct sunlight, as this may damage the printer.
- When moving the printer, remove the toner cartridges. Do not reuse toner cartridges once you have removed them from the printer. Loose toner can spill inside the printer and deteriorate print quality.
- Do not place the printer directly next to an air conditioner or heater, as this affects the temperature inside the printer and can cause damage.
- Do not use the printer when it is tilted at an angle of more than 5 degrees, as this may result in damage.

Precautions for Power and Ground (earthed) Connections

WARNING



Use the printer within the specified power range.

AC power: 100-127 VAC \pm 10% (90V-140V) or 220-240 VAC \pm 10% (198V-264V)

Frequency: 50 \pm 3Hz/60 \pm 3Hz



Ensure that the power cord connector and power socket are free of dust. In a damp environment, a contaminated connector can, over time, draw non-negligible amounts of current that can generate heat and eventually cause fire.



Do not attempt to modify, pull, bend, chafe, or otherwise damage the power cord. Do not place objects on the power cord. A damaged power cord can cause fire or electric shocks.



Never touch a power cord with wet hands. This constitutes an electric shock hazard.



In the following situations, stop using the printer immediately, turn it off, and disconnect the power cord from the socket. After that, contact your dealer or authorized Brother service representative immediately. Continued use of the printer in such situations could result in fire.

- There is smoke emanating from the printer or the outside of the printer is excessively hot.
- Unusual noises are coming from the printer.
- There is water inside the printer.



To prevent fire or electric shocks, connect the green earth wire bundled with the power cord to one of the following:

- The earth terminal of the power outlet
- A piece of copper buried in the earth 650 mm or deeper

Make sure that the earth wire on the power cord is connected before you use the printer. If it is not possible to make an earth connection, consult your dealer or Brother authorized service representative.

Never connect the earth wire to any of the following:

- Gas pipes that could ignite and explode
- Telephone line earth wires or lightning rods, which can draw an excessive electric current if hit by lightning
- Water faucets or pipes whose electrical conductivity is broken by a non-metallic part



If the power cord is broken or insulated wires are exposed, ask your dealer or authorized Brother service representative. Using a damaged cord can cause fire or electric shocks.

CAUTION



Do not plug or unplug the printer when it is on. Unplugging a live connector can deform the plug and cause fire.



When unplugging the printer, grasp the plug instead of the power cord. Forcibly pulling the power cord can damage it and cause a fire or electric shocks.



Be sure to turn off and unplug the printer before accessing the interior of the printer for cleaning, maintenance, or troubleshooting. Accessing the interior of a live printer can result in electric shocks.



Once a month, turn off the printer and check the power cord for the following. If you notice any unusual conditions, contact your dealer for assistance.

- The power cord is plugged firmly into the power outlet.
- The plug is not excessively heated, rusted, or bent.
- The plug and outlet are dust free.
- The cord is not cracked or frayed.



When the printer is not used over an extended period of time, switch it off and unplug it. When an unused printer is left connected to a power source for a long period, degraded insulation can cause electric shocks, current to leak, or fire.



Switch off the printer before connecting the interface cable or options. Connecting the interface cable or options to a live printer can cause electric shocks.

Other

- **Radio interference**
This printer may interfere with radio or television reception, causing flickering or distortion. This can be determined by turning the printer off and on. To correct interference, perform one or a combination of the following procedures:
 - Move the printer away from TV and/or radio.
 - Reposition the printer, TV and/or radio.
 - If the printer, TV and/or radio are plugged to the same socket, unplug them, then plug them into different sockets.
 - Reposition the TV and/or radio antennas and cables until the interference stops. For external antennas, consult your local electrician.
 - Use coaxial cables with radio and television antennas.

Operating Precautions

WARNING



Do not place any liquid containers such as vases or coffee cups on the printer. Liquids spilt on the printer can cause a fire or electric shock.



Do not place any metal parts such as staples or clips on the printer. If metal or flammable materials get into the printer, they can short circuit internal components and cause a fire or electric shocks.



If debris (metal or liquid) gets into the printer, turn off and unplug the printer. After that, contact your dealer or authorized Brother service representative immediately. Operating a debris-contaminated printer can cause a fire or electric shocks.



Never open or remove printer covers that are secured with screws unless specifically instructed to do so in the this guide. High-voltage components can cause electric shocks.



Do not try to alter the printer's structure or modify any parts. Unauthorized modifications can cause fire.



This printer complies with the IEC60825 (Class 1) international laser standard. This means that the printer does not present any risk of injury to individuals from laser radiation. Various covers confine the laser radiation to the inside of the printer; hence, users cannot incur injury from the laser under normal operating conditions. Removing covers, unless instructed to do so in this guide, can cause injury from laser radiation.

CAUTION



Never touch an area indicated by a high-temperature warning label (on or near the fuser unit). Touching these areas may result in burns.

If a sheet of paper is wrapped around the fuser or rollers, do not use excessive force to remove it so to avoid injuries or burns. Turn off the printer immediately and contact your dealer or authorized Brother service representative.



Do not place any heavy objects on the printer. An off-balance printer can fall over or the heavy object can fall, resulting in injuries.



Do not use highly flammable sprays or solvents in or around the printer, as this can result in fire.



When removing paper jams, make sure that no pieces of paper are left inside the printer, as this can cause fire.

If the paper is wrapped around the fuser or roller, or you cannot see the jam that you are trying to clear, do not attempt to remove the paper by yourself, as this may result in injuries or burns. Turn off the printer immediately and contact your dealer or authorized Brother service representative.



Do not place magnetic objects near the safety switch of the printer. Magnets can activate the printer accidentally, resulting in injuries.

Others

Refer to this guide for procedures on clearing paper jams and how to resolve any other problems that may occur.

Notes on Handling Consumables

WARNING



Never put a toner cartridge into an open flame. It can explode, resulting in injuries.



Never put a transfer roll cartridge into an open flame. It can explode, resulting in injuries.



Never put a print head cartridge into an open flame. It can explode, resulting in injuries.

Others

- Do not open consumables until you are ready to use them. Do not store consumables in the following conditions:
 - Hot or humid areas
 - Near a naked flame
 - Exposed to direct sunlight
 - Dusty areas
 - Before using consumables, read the instructions and precautions provided with the consumables.
- Administer emergency first aid as follows:
 - If you get toner in your eyes, rinse them abundantly in clean water and consult your physician, if necessary.
 - If you get toner on your skin, wash it with soap and water. Rinse well.
 - If you inhale toner, leave the contaminated area immediately and gargle with water.
 - If you swallow toner, induce vomiting and consult your physician immediately.

- When you remove the transfer roll cartridge from the printer because the waste toner collection box is full, do not attempt to empty the waste toner box and reuse the cartridge, as toner may spill inside the printer and cause damage. Loose toner can spill inside the printer and deteriorate print quality.
- Do not tilt or shake the print head cartridges or transfer roll cartridges when removing them temporarily. Loose toner can spill inside the printer and deteriorate print quality.

CHAPTER 1

PRINTER SYSTEM SETTINGS

1.1 Adjusting Color Registration

Follow the procedure below to adjust the color registration when you first install the printer or after moving it to a new location.

 **See**

Refer to 5.2 “Basic Menu Operation” for information about the operation of the control panel.

❖ Printing the Color Registration Chart

Use the control panel to print the color registration chart.

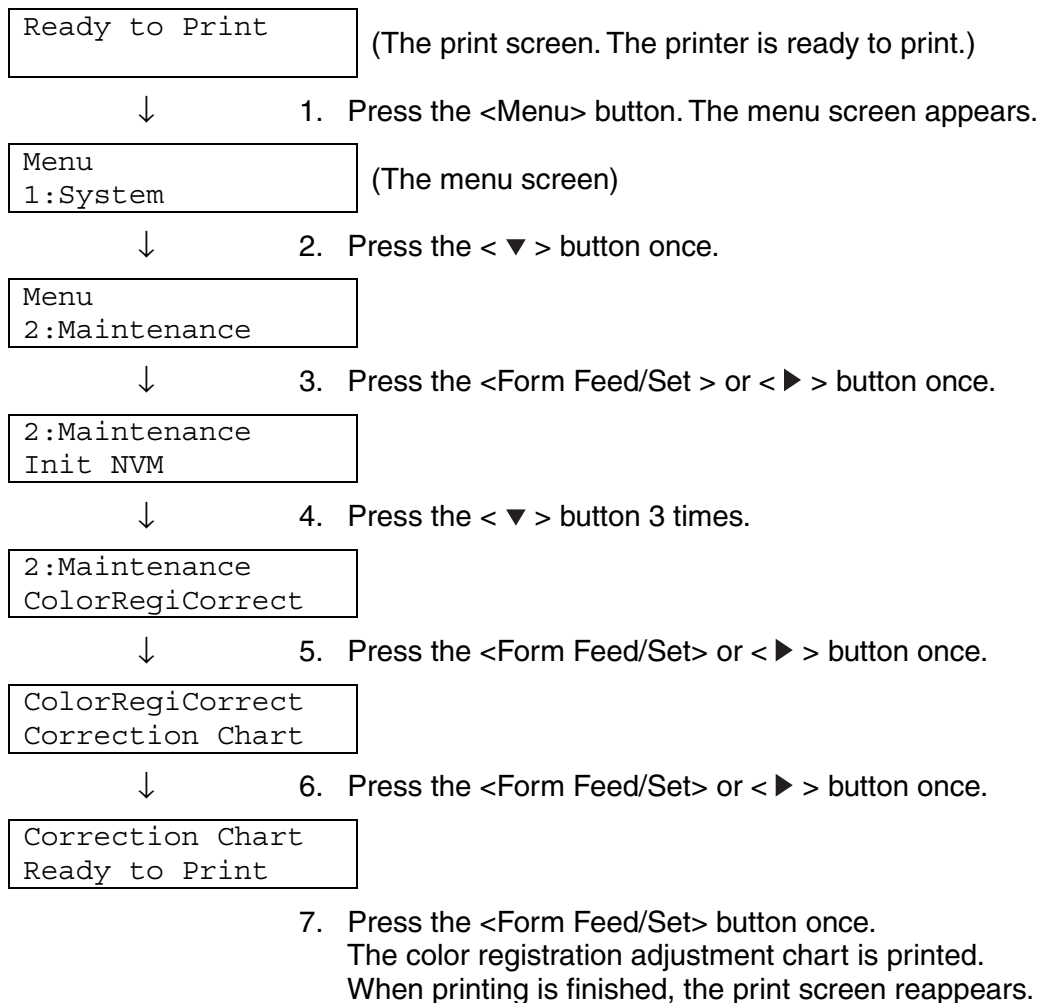

❖ **Determining values**

From the lines to the right of the Y (yellow), M (magenta), and C (cyan) pattern, find the values of the straightest lines.

⇒ **Note**

You can also use the densest colors of the grid to find the straightest lines. The colors printed at the highest density are those next to the straightest lines. When '0' is the value nearest the straightest line, you do not need to adjust the color registration. When the value is not '0', follow the procedure outlined in "Entering Values".

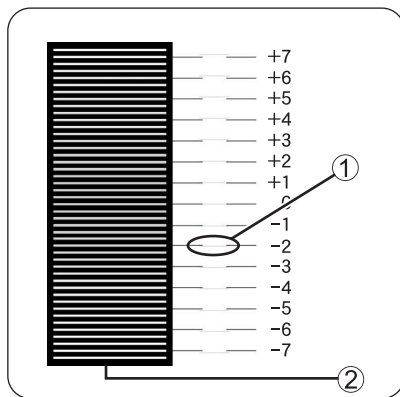

1. Straightest line
2. Lattice pattern

❖ **Entering Values**

Using the control panel, enter the values that you found in the color registration chart to make adjustments.

Ready to Print



1. Follow steps 1 through 5 on the previous page to display the color registration chart settings menu.

ColorRegi Correct
Correction Chart



2. Press the < ▼ > button once.

ColorRegi Correct
Enter Number



3. Press the < Form Feed/Set > or < ▶ > button once.

Continued

Continued from the previous page.



```
Enter Number
Y= 0 M= 0 C= 0
```

4. Using the < ▼ > or < ▲ > buttons, press the buttons until you reach the value (for example, +3) displayed on the chart.



```
Enter Number
Y=+3 M= 0 C= 0
```

5. Press the < ► > button once and move the cursor to



```
Enter Number
Y=+3 M= 0 C= 0
```

6. Repeat steps 4 and 5 to continue setting the color registration.



```
Enter Number
Y=+3 M=+1 C=+2
```

7. Press the <Form Feed/Set> button once.



```
Correction Chart
Ready to Print
```

8. Press the <Form Feed/Set> button once.
The color registration chart is printed with the new values.
When printing is finished, the print screen reappears.
9. Color registration adjustment is complete when the straightest Y (yellow), M (magenta), and C (Cyan) lines are next to the '0' line.

⇒ **Note**

After printing the color registration chart, do not turn off the printer until the printer motor has stopped running.

1.2 Configuring the Printer on a Network

This section describes configuring the printer for a network connection.

1.2.1 Setting an IP Address

This section describes the procedure for setting the IP address, subnet mask, and gateway address from the control panel of the printer. Follow the steps below.

Look

IP addresses are managed throughout the system as a whole. Specifying the wrong IP address can affect the entire network. Before setting an IP address, consult your system administrator.

See

Refer to 5.2 “Basic Menu Operation” for further information about the operation of the control panel.

❖ **Set the IP address acquisition method to ‘Panel’.**

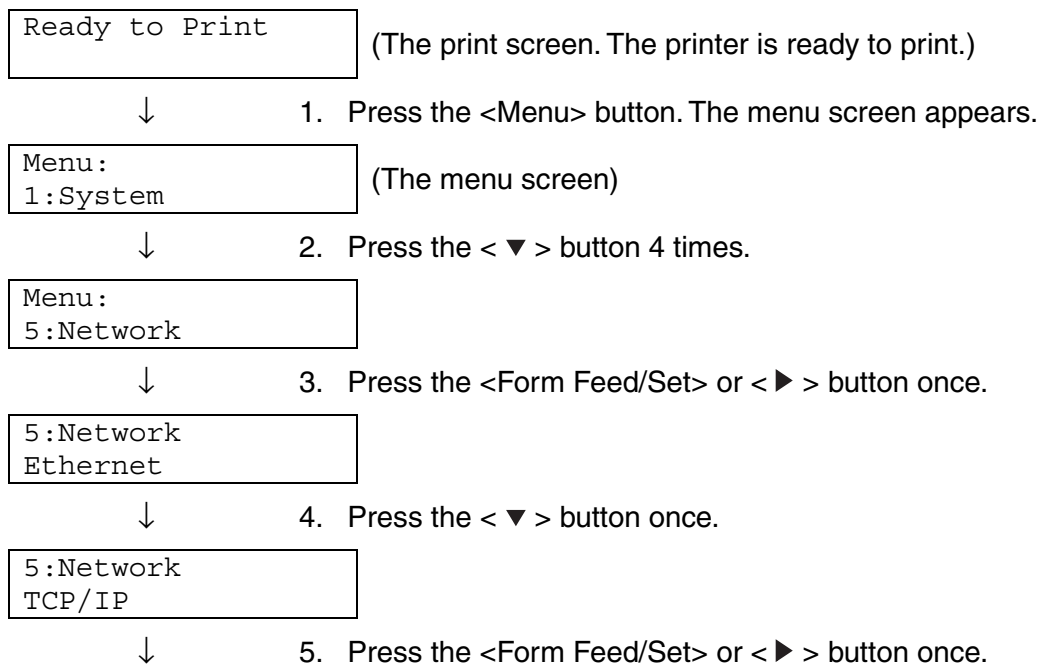

Continued

Continued from the previous page.



```
TCP/IP
Setup IP Address
```



6. Press the <Form Feed/Set> or <▶> button once.

```
Setup IP Address
DHCP *
```

The value currently set has a '*' displayed next to it.



7. Press the <▼> button once.

```
Setup IP Address
Panel *
```



8. Press the <Form Feed/Set> button once.

```
Reboot system
To take effect
```



3 seconds later, the following screen appears.

```
Setup IP Address
Panel *
```

When the value is set, a '*' appears next to it.

9. Press the <Job Cancel/Back> or <◀> button once. The lower line of the screen returns to the 'Setup IP Address'.



 **Look**

Only restart the printer after setting the gateway address at the last step. Continue to the next step without restarting the printer.

❖ **Setting the IP Address**

⇒ **Note**

The IP address consists of four separate values (base 10) separated by decimal points. The 4 values can be set anywhere between 0 and 255.

Continued from the previous step

TCP/IP
Setup IP Address



10. Press the < ▼ > button once.

TCP/IP
IP Address



11. Press the <Form Feed/Set> or < ► > button once.

IP Address
000.000.000.000*



12. Using the < ▲ > or < ▼ > button, press the buttons until the desired value (for example, 192) appears. You can hold down the buttons to change the value in increments of 10.

IP Address
192.000.000.000



13. Press the < ► > button once and move the cursor to the next value.

IP Address
192.000.000.000



14. Repeat steps 12 and 13 to finish setting the IP address.

IP Address
192.168.001.100



15. Press the <Form Feed/Set> button once.

Reboot system
To take effect



3 seconds later, the following screen appears.

IP Address
192.168.001.100*



16. Press the <Job Cancel/Back> or < ◀ > button once. The lower line of the screen returns to 'IP address'.

Example:

- IP Address '192.168.1.100'
- Subnet mask '255.255.255.0'
- Gateway Address '192.168.1.254'

❖ **Setting the Subnet Mask**

Continued from the previous step



```
TCP/IP
IP Address
```



17. Press the < ▼ > button once.

```
TCP/IP
Subnet Mask
```



18. Press the <Form Feed/Set> or < ► > button once.

```
Subnet Mask
000.000.000.000*
```



19. Set the subnet mask in the same way as the IP address.
To set values with the < ▲ > or < ▼ > buttons, you can hold down the button to change the value sequentially.

```
Subnet Mask
255.255.255.000*
```



20. Press the <Job Cancel/Back> or < ◀ > button once.
The lower line of the screen returns to 'Subnet Mask'.

❖ **Setting the Gateway Address**

Continued from the previous step



```
TCP/IP
Subnet Mask
```



21. Press the < ▼ > button once.

```
TCP/IP
Gateway Address
```



22. Press the <Form Feed/Set> or < ► > button once.

```
Gateway Address
000.000.000.000*
```



23. Set the gateway address in the same way as the IP address. To set values with the < ▲ > or < ▼ > buttons, you can hold down the button to change the value sequentially.

```
Gateway Address
192.168.001.254*
```

24. At this point, restart the printer.

1.2.2 Setting Protocols

Look

When the printer is shipped from the factory, all protocols except FTP' are active by default. Normally you do not need to perform the operations described in this section when you connect a new printer to a network for the first time. If you need to change any of the default Protocol settings, follow the steps outlined in this section. This concludes the printer settings. Move on to 1.2.3 "Confirming Settings".

Supported Protocols

- For TCP/IP(LPD) → [LPD] protocol
- For port 9100 → [Port9100] protocol
- For IPP → [IPP] protocol
- For NetBIOS (transport protocol: TCP/IP) → [NetBIOS TCP/IP] protocol
- For NetBIOS (transport protocol: NetBEUI) → [NetBIOS NetBEUI] protocol
- For NetWare → [NetWare] protocol
- For AppleTalk → [AppleTalk] protocol

See

Refer to 5.2 "Basic Menu Operation" for information about the operation of the control panel.

❖ **Changing Protocol Settings**

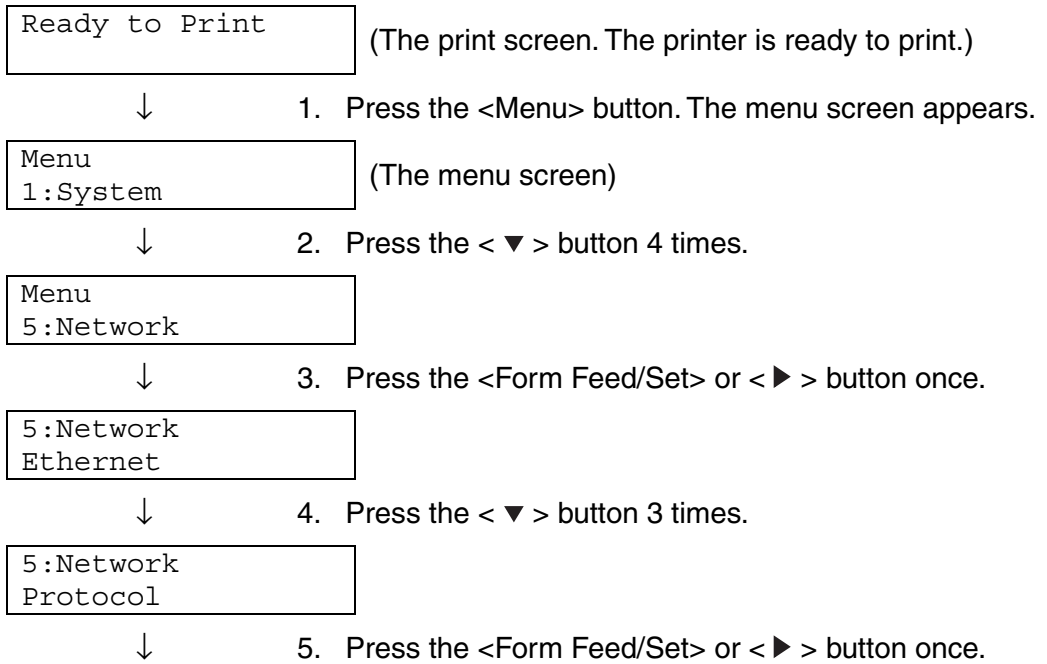

Continued

Continued from the previous step



Starting protocols

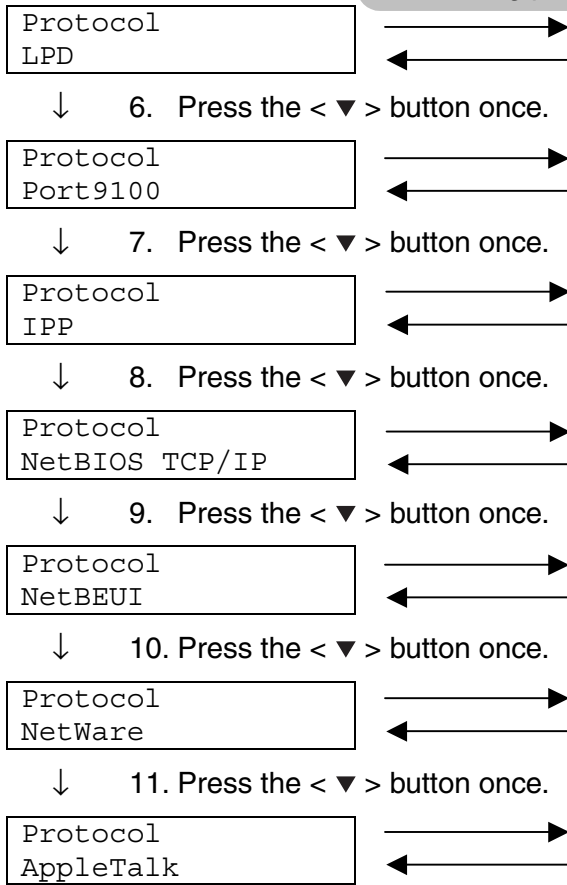

1. Press the <Form Feed/Set> button once. XXX indicates the protocol name.

XXX
Disabled *

2. Press the <▼> button once.

XXX
Enabled

3. Press the <Form Feed/Set> button once. 'Reboot system to take effect' appears for 3 seconds, then following screen appears.

XXX
Enabled *

4. To start other protocols, press <Job Cancel/Back> or the <◀> button once and continue to the next step.

To finish the setting procedure, go to step 12.



12. Restart the printer.

1.2.3 **Confirming Settings**

Print the settings list to check the content of printer settings.

The printer settings list also contains information that is required when configuring computers for printing. Use the list to confirm that settings on the printer and the computer match.

 **See**

For details about printing the settings list, refer to 8.4.1 “Confirming Printer Configuration and Network Settings”.

CHAPTER 2

INSTALLING THE PRINTER DRIVER

2.1 Installing the Printer Driver (Windows)

The printer driver is software that converts print and command data into forms usable by the printer.

When using the printer locally, install the printer driver on the computer connected to it. To share a printer through a network, install the printer driver on every computer connected to the network.

2.1.1 Installing the Printer Driver

To Install the Windows printer driver, see the Setup Guide.

2.1.2 Upgrading the Printer Driver

Printer driver upgrades are available on the Brother Solutions Center. To use the software, download it.

Any connection charges incurred while downloading the software are entirely the customer's responsibility.

Follow the procedure below to install the Windows printer driver upgrade

- 1.** On the Start menu, point to Settings and click Printers.
The Printers window opens.
- 2.** Click the appropriate printer and on the File menu, click Properties.
The Properties dialog box opens.
- 3.** Click Paper/Output tab.

4. Click Brother Solutions Center.

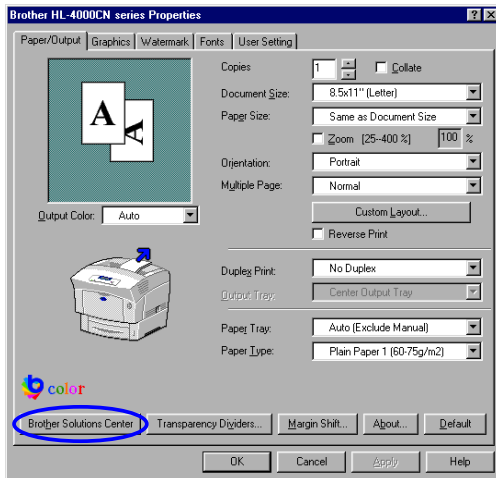

The browser starts and accesses the Brother Solutions Center.

5. Follow the instructions on the screen to download the appropriate printer driver.

6. To close the properties dialog box, click OK.

⇒ **Note**

-
- You can also use the CD-ROM provided to access the Brother Solutions Center and download the printer driver.
 - The address of the Brother Solutions Center is:
<http://solutions.brother.com>
 - Any connection charges incurred while downloading the software are entirely the customer's responsibility.
-

2.2 *Installing the Printer Driver (Macintosh)*

Printer drivers for both USB and AppleTalk network connections are provided with your Brother printer.

You can install the printer driver on Macintosh computers that meet the following conditions:

- The printer is connected with a USB cable and the computer runs Mac OS 8.6 to X with a standard USB interface. (However, we cannot guarantee the normal operation of all USB-compatible equipment.)
- The printer is connected to a network and computers are running Mac OS 8.1 to X.
- The machine is configured as an AppleTalk client.

See

For details about how to set up an AppleTalk client, refer to the literature accompanying your Macintosh computer.

Look

It is not possible to use Apple QuickDraw GX on the system when using the printer.

2.2.1 *Installing the Printer Driver*

To install the Macintosh printer driver, see the Setup Guide.

2.2.2 *Upgrading the Printer Driver*

Printer driver upgrades are available on the Brother Solutions Center. To use the software, download it.

Any connection charges incurred while downloading the software are entirely the customer's responsibility.

The address of the Brother Solutions Center is:

<http://solutions.brother.com>

CHAPTER 3

BASIC PRINTER OPERATION

3.1 Printer Part Names and Functions

The names and functions of the various parts of the printer are as follows:

❖ Front View

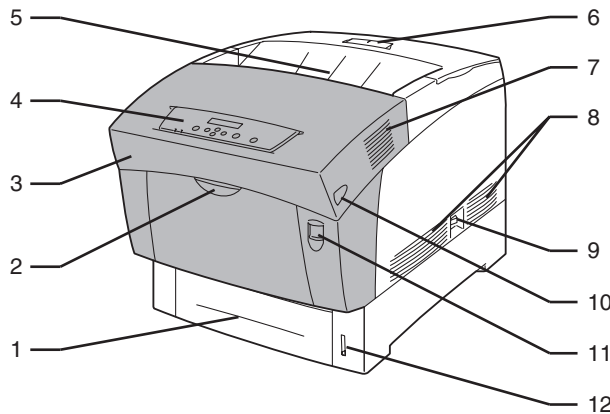

No.	Name	Description
1	Paper Tray	Load paper here.
2	Multi-purpose Tray (MP Tray)	Use this tray to load items such as cards and envelopes manually.
3	Front Cover	The shaded part of the illustration above. Open to clear paper jams, replace the print head cartridge, or transfer roll cartridge.
4	Control panel	Use the buttons and display to control the printer.
5	Face Down Tray	Printed documents are output here, printed side facedown.
6	Paper Stopper	Lift to prevent paper from falling when it is printed.
7	Exhaust Grille	Allows internal heat to dissipate. Make sure that the exhaust grilles are never obstructed.
8	Ventilation Intake Grille	Allows air to enter the printer to prevent it from overheating. Make sure that the ventilation intake grilles are never obstructed.
9	Power Switch	The printer's power switch. Press [I] to turn on the printer and [O] to turn it off.
10	Button B	Use button B to open the upper part of the front cover.
11	Button A	Use button A to open the whole front cover.
12	Paper Meter	Use the meter as a guide to refill the paper tray.

❖ Rear View

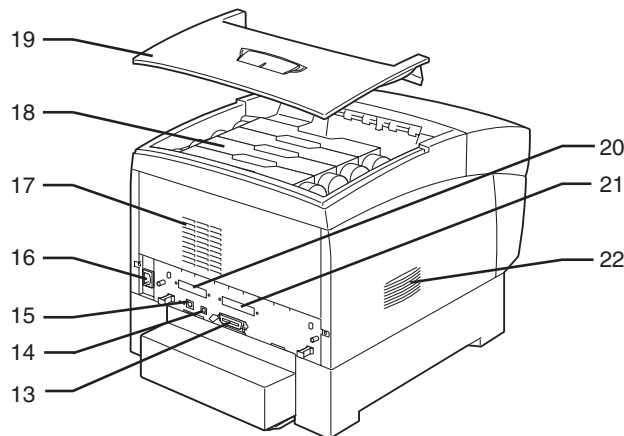

No.	Name	Description
13	Parallel Interface Connector	To use the printer locally, connect the parallel cable here.
14	USB Interface Connector	To use the printer locally, connect the USB cable here.
15	Ethernet Interface Connector	To use the printer through a network, connect the Ethernet cable here.
16	Power Cord Connector	Connect the power cord here.
17	Exhaust Grille	Allows internal heat to dissipate. Make sure that the exhaust grilles are never obstructed.
18	Toner Cartridges	Insert the black, yellow, magenta, and cyan toner cartridges here.
19	Top Cover (face down tray)	This is the printer's top cover. Remove it to change the toner cartridges. It acts as the top cover and the face down tray of the printer. Printed documents are output here, printed side facedown. Do not use the printer without the top cover.
20	Slot for the network expansion card	Network expansion card is installed here.
21	Option Slot (for the optional hard disk)	Install the optional hard disk here.
22	Ventilation Intake Grille	Allows air to enter the printer to prevent it from overheating. Make sure that the ventilation intake grilles are never obstructed.

❖ Internal View

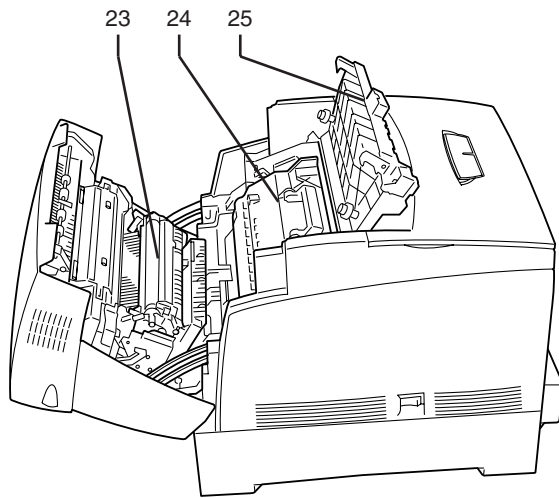

<Cover open with button A>

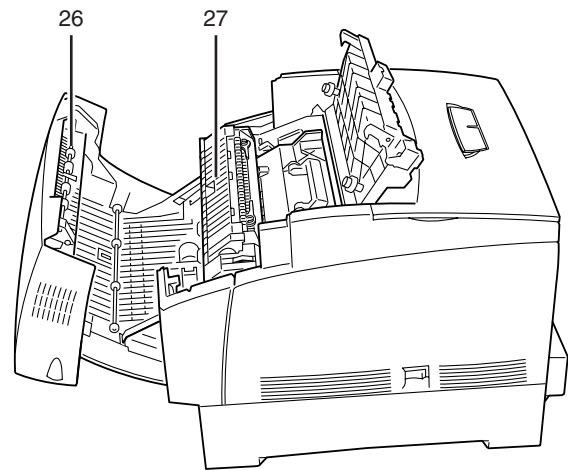

<Cover open with button B>

No.	Name	Description
23	Transfer roll cartridge	Transfers the image created on the print head surface to the paper and collects used toner.
24	Print Head Cartridge	Consists of a light-sensitive print head, developer, and a transfer roller. Images are initially created as an electrical charge on the surface of this drum.
25	Paper outlet cover	Open to replace the print head cartridge and fuser unit.
26	Paper rotator	With duplex printing, it turns the paper over after the front side has been printed.
27	Fuser Cartridge	Uses heat to fuse the toner to the paper. The fuser unit gets very hot during printing. Do not touch. Touching the fuser cartridge can cause burns.

3.2 Turning the Printer On and Off

3.2.1 Turn the Printer On

To turn on the printer, follow the procedure below.

1. On the printer's right side, press the side of the power switch marked [I] to turn on the printer. The printer starts.

⇒ **Note**

The printer motors warm up for 1 or 2 minutes when you turn on the printer.

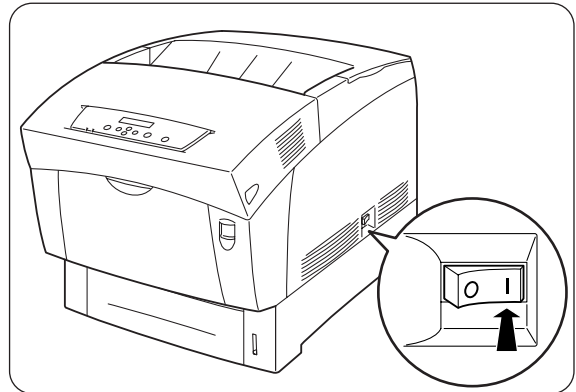

2. “Testing” appears on the control panel. When the display changes from “Please Wait...” to Ready to Print, check that the print Ready lamp is lit.

⇒ **Note**

When “Please Wait...” is displayed, the printer is preparing to print. Printing is not possible while this message is displayed.

☞ **Look**

If an error message appears on the display, refer to 6.7 “What to Do When an Error Message Appears” and rectify the error as instructed.

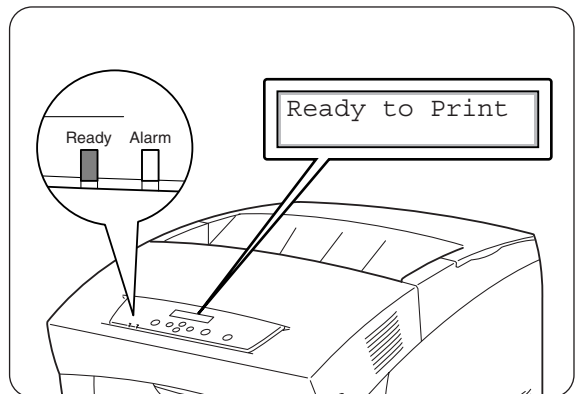

3.2.2 Turn the Printer Off

To turn off the printer, follow the procedure below.

1. Confirm that “Ready to Print” is displayed on the control panel.

Look

Do not turn off the printer in the following situations:

- Data Wait is displayed on the control panel.
- The Ready lamp is blinking.
- The Alarm lamp is on.

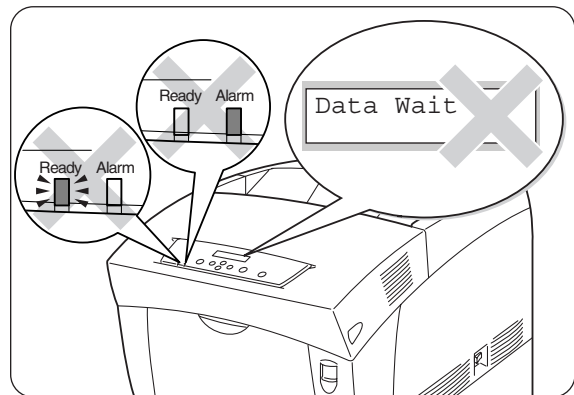

2. On the printer's right side, press the side of the power switch marked [O] to turn off the printer. The printer is now off.

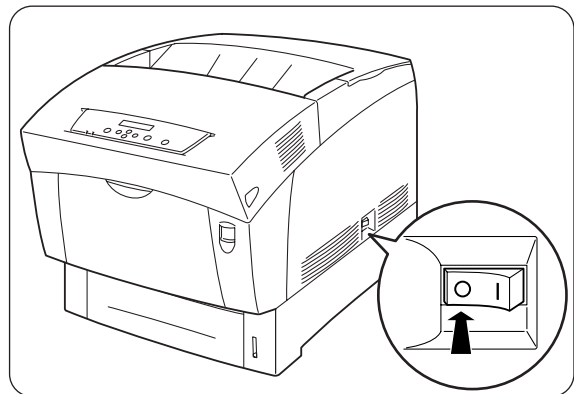

3.3 *Printing from a Computer*

This section describes the procedures to print from computers depending on the type of operating system used.

Look

When you install new printer options, you must reconfigure the printer driver to use the options. To confirm or make the settings, refer to 3.6 “Changing Configuration for Options”.

3.3.1 *In Windows*

Printing from a program

You can output jobs to the printer from most Windows programs with their print command.

The following is a description of printing from Microsoft Word 97 in Windows 98.

Note

How to access dialog boxes and their contents vary depending on the operating system and programs you are using. For details, refer to the literature provided with the program you are using.

1. On the File menu, click Print.
The Print dialog box appears.
2. Select this printer in the Printers box and click Properties.
3. On the various tabs, make settings for each item as required.

See

For details about the tabs, refer to Help. For details about how to use Help, refer to 3.4 “Using Help”.

4. When you finish making settings, click OK in the Properties dialog box. The Properties dialog box closes.
5. In the Print dialog box, select the desired interval in [Page range] and click OK. The data is sent to the printer.

 **See**

To cancel printing, refer to 3.5 “Cancel Printing”.

❖ **Changing default printing functions**

Default printing functions are preset functions in the printer driver properties dialog box accessed from the Print dialog box. Setting default printing functions in advance saves you time, because it reduces the number of settings you need to make every time you print.

Follow the procedure below to change the default printing functions. The following example is for Windows 98.

⇒ **Note**

How to access dialog boxes and their contents vary depending on the operating system and programs you are using.

1. On the Start menu, point to Settings and click Printers. The Printers window opens.
2. Click the appropriate printer and on the File menu, click Properties. The Properties dialog box opens.

⇒ **Note**

-
- In Windows 95 and Windows Me, you can open the Properties dialog box the same way as in Windows 98.
 - In Windows NT 4.0, click [Document Defaults...] on the File menu and make the settings in the dialog box that appears.
 - In Windows 2000/XP, click [Printing Preference...] on the File menu and make the settings in the dialog box that appears.
-

3. On the various tabs, make settings for each item as required.

 **See**

For details about the various tabs, refer to Help. For details about how to use Help, refer to 3.4 “Using Help”.



4. When you finish making settings, click OK in the Properties dialog box. The default printer functions in the printer driver are now changed.

3.3.2 With a Macintosh Computer

The following is a description of printing from Microsoft Word 98.

⇒ **Note**

How to access dialog boxes and their contents vary depending on the operating system and programs you are using. For details, refer to the literature provided with the program you are using.

1. On the File menu, click Paper Settings.
The Paper Settings dialog box appears
2. Use the  buttons next to Paper Settings to select the settings that you want to make.
Configure the items in each dialog box as necessary and click OK.
3. On the File menu, click Print.
The General Settings dialog box appears.
4. Use the  buttons next to General Settings to select the settings that you want to make.
Configure the items in each dialog box as necessary.

See

- For details about the dialog box elements, refer to Balloon Help. For details about how to use Balloon Help, refer to 3.4 “Using Help”.
 - Use the General settings dialog box to adjust the image and colors to suit your needs.
-

5. When you finish making your settings, click Print.
The data is sent to the printer.

See

To cancel printing, refer to 3.5 “Cancel Printing”.

3.4 *Using Help*

Help for the printer is provided with the printer driver. Refer to Help when you need to know about printer driver items and settings, or need to check different printing methods when problems occur.

3.4.1 Referring to Windows Help.

- ❖ **To refer to Help, open the Properties dialog box and select the tab that contains the item in question.**

The example below is for the Paper/Output tab in Windows 98.

See

For details about how to display the Properties dialog box, refer to 3.3 “Printing from a Computer”.

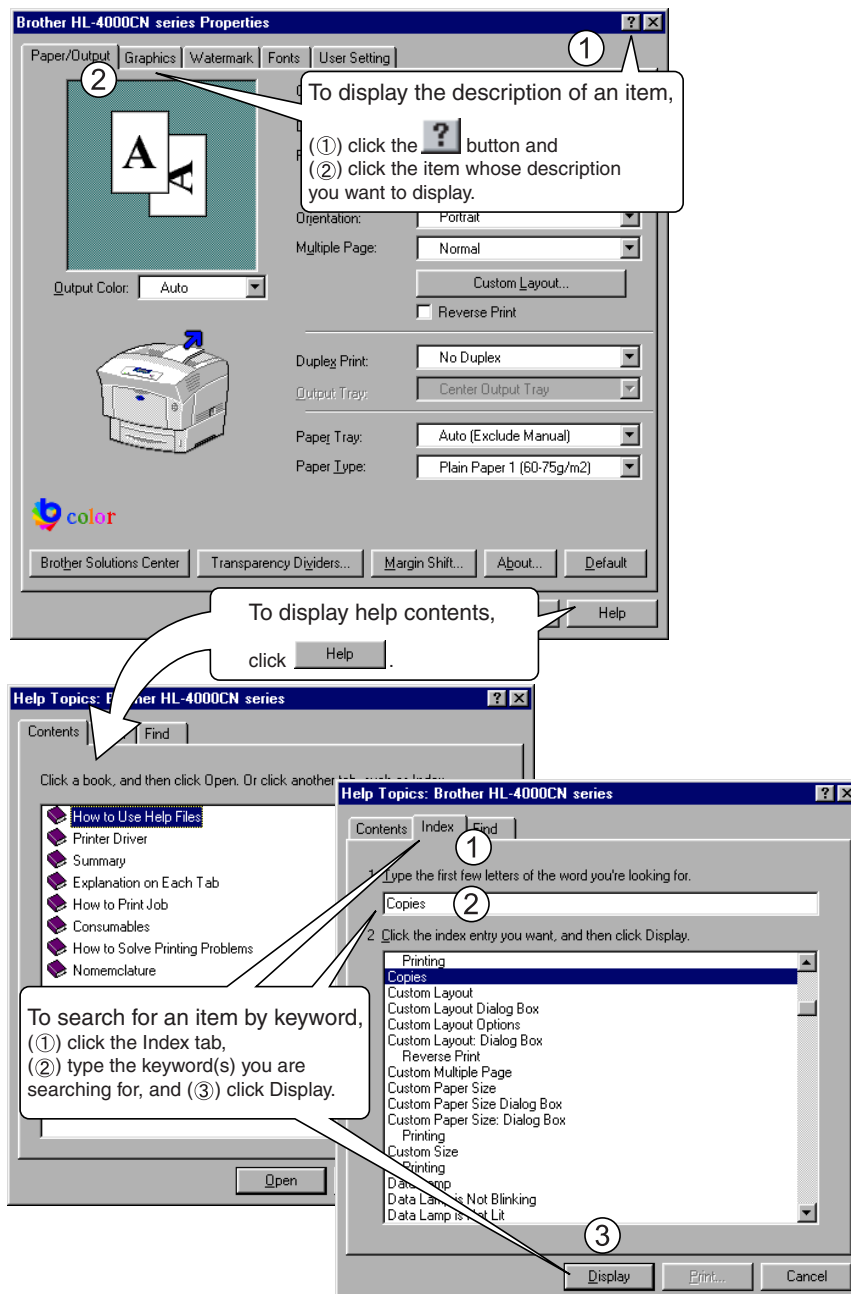

3.4.2 Referring to Balloon Help on Macintosh.

Balloon Help is provided with the Macintosh printer driver. Use Balloon Help to find out the functions of individual items. To refer to Balloon Help, display the dialog box that contains the item in question. The example given is for the General Settings dialog box.

See

For details about how to display the Properties dialog box, refer to 3.3 “Printing from a Computer”.

1. Click [Show Balloons] on the Help menu of the Menu bar.
2. Move the mouse to the item in question. A description of the item appears.

Note

To hide Balloon Help, click [Hide Balloons] on the Help menu on the Menu bar.

3.5 Cancel Printing

To cancel printing, first cancel the computer print command.
Next, use the control panel to cancel printing from the printer.

3.5.1 Cancel Printing on the Computer

The procedure to cancel printing differs depending on the type of operating system you are using.

❖ In Windows

Follow the procedure below.

- 1.*** On the Start menu, point to Settings and click Printers.
The Printers window opens.
- 2.*** Double-click the appropriate printer.
The printer window appears.
- 3.*** Click the document that you want to cancel and press the Delete key on the keyboard.

Continue to 3.5.2 “Cancel Printing from the Control Panel”.

❖ *On a Macintosh Computer*

1. Double-click the printer icon on the Desktop.
2. Select the document that you want to cancel and click ().
Continue to 3.5.2 “Cancel Printing from the Control Panel”.

3.5.2 Cancel Printing from the Control Panel

Perform this operation to cancel the print data from the printer after canceling the print command on the computer. Note that the printer finishes printing the current page.

 **See**

For details about control panel operations, refer to 5.2 “Basic Menu Operations”.

Printing	PCL6
LPD	Tray1

(The printer is printing)



1. Press the <Job Cancel/Back> button once.
The printer begins to process the printing cancellation.

Cancelling



When the cancellation finishes, the print screen reappears.

Ready to Print

(The print screen. The printer is ready to print.)

3.6 Changing the Configuration for Options

Once you make the initial configuration of the printer, you must reconfigure the printer driver when you install the following options.

1. 2 Tray Module
2. Hard disk
3. Memory expansion

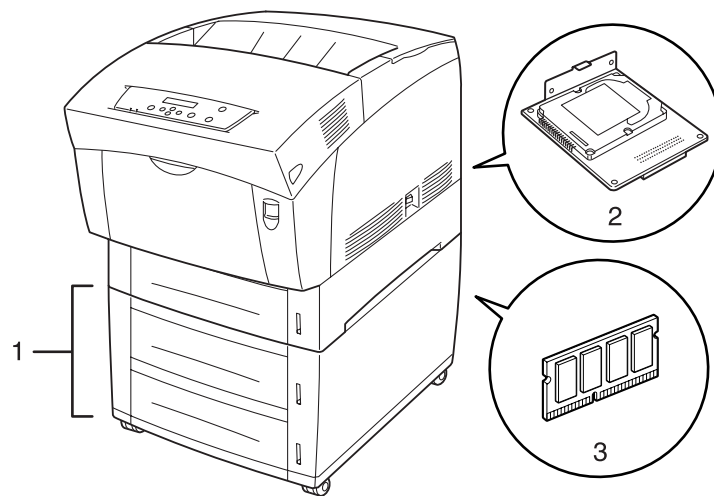

 See

For details about how to install options, refer to the literature provided with the options. In the following section, it is assumed that the options are already installed.

Memory expansion

In general, DIMM must have the following specifications:

Type: 144pin and 64bit output
CAS Latency: 100MHz or more
Capacity: 64Mbyte-256Mbyte
Dram Type: SDRAM 2 Bank

The following DIMM size can be installed:

<US>

64 MB	TECHWORKS	VN133-64M
128 MB	TECHWORKS	VN133-128M
256 MB	TECHWORKS	VN133-256M

<Europe>

64 MB	Buffalo Technology	VN133-64M
128 MB	Buffalo Technology	VN133-128M
256 MB	Buffalo Technology	VN133-256M

3.6.1 In Windows

Follow the procedure below. The following example is for Windows 98.

- 1.** On the Start menu, point to Settings and click Printers.
The Printers window opens.
- 2.** Click the appropriate printer and on the File menu, click Properties.
The Properties dialog box opens.
- 3.** Click the Printer Configuration tab.
- 4.** Select the options added to the printer and click OK.

3.6.2 On a Macintosh computer

Follow the procedure below.

1. On the Apple menu, select Selector.
The Selector window appears.
2. Click the printer that you want to use in the upper right of the Selector window.

<USB cable connection>

Click 'LaserWriter8' and follow the instructions.

<AppleTalk system>

3. Select the printer that you want to set from the list under Connect to, then click Setup.

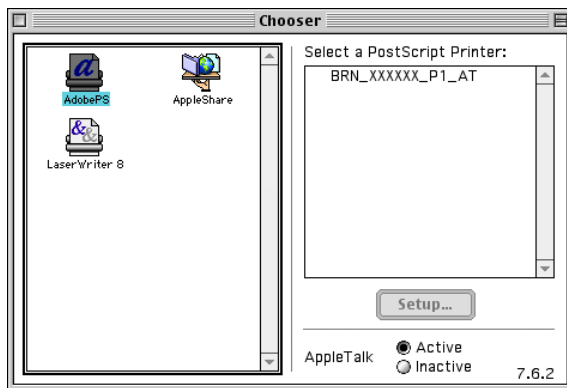

4. In the Connect to dialog box, select the options that you want to add and click OK.
5. Close the Selector window.

3.7 Printing on Envelopes, Transparency Sheets, and Custom-size (Long) Paper

Take care when setting cards and envelopes, because setting them incorrectly may result in printed side or text direction errors.

When printing on transparency sheets or specialty paper, make sure that you set the type of paper and image quality before sending the print command.

⇒ **Note**

When frequently printing specialty paper in Windows, we recommend that you register the necessary settings in the User Settings tab.

Registering the settings saves you time, because you do not need to configure the driver each time you print. For details about the User Settings tab, refer to Help.

3.7.1 Printing on Envelopes

Use the multi-purpose tray to print envelopes.

☞ **Look**

- Do not use envelopes with tape seals. Printing some types of preglued envelopes may not be possible, depending on the condition of the adhesive. We recommend using envelopes designed for *laser* printers.
 - Do not use envelopes larger than 88.9 mm (3.5 in.) wide and 139.7 mm (5.5 in.) long.
 - Using poor-quality envelopes can cause creasing and deteriorate print quality.
-

The following is an example of how to print the address on an envelope.

Example

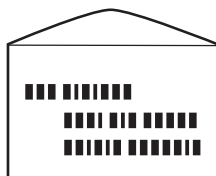

printed like this.

1. Adjust the paper guide to the mark corresponding to the size of envelope you are about to use.
2. Make sure the flap is closed, load the envelope with the side to be printed facing down, and the flap facing right.
3. Launch printing from your program after setting the envelope in the printer. Now set the items in “Printer Driver Settings (for envelopes)” as shown below:

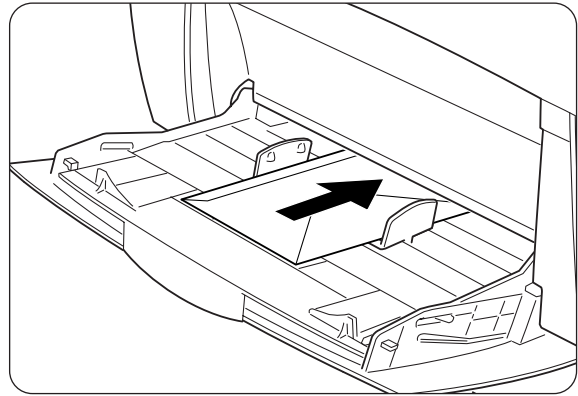

❖ **Printer Driver Settings (for envelopes)**

Windows settings

Tab	Item	Setting
Paper/Output	Paper Size	Com-10 Monarch C5 DL Same as Document Size (When the documentation size is Com-10, Monarch, C5 or DL)
	Reverse Print	Turn on if necessary.
	Duplex Print	OFF
	Paper Tray	MP Tray
	Paper Type	Envelope

Macintosh settings

Dialog Box	Item	Setting
Paper Settings	Paper Size	Com-10 Monarch C5 DL Same as Document Size (When the documentation size is Com-10, Monarch, C5 or DL)
	Reverse Print	Turn on if necessary.
	Paper Tray	Envelope
	Duplex Print	OFF
Printer Settings	Paper Type	MP Tray

⇒ **Note**

For details about individual printer driver items, refer to Help. For details about how to use Help, refer to 3.4 “Using Help”.

3.7.2 Printing on Transparency Sheets

Use the multi-purpose tray to print transparency sheets.

Look

Use only the recommended type of transparency sheets (3M CG3300). Do not use any other types, such as color transparency sheets (bordered with a white frame). Using unsuitable transparency sheets may damage the printer.

Do not use transparency sheets bordered with a white frame.

Look

Remove each transparency sheet from the face down tray as soon as it is output. When transparency sheets are allowed to accumulate in the face down tray, static electricity can build up and cause jams.

Follow the procedure below to print transparency sheets.

1. Adjust the paper guide to the mark corresponding to the size you are about to use.

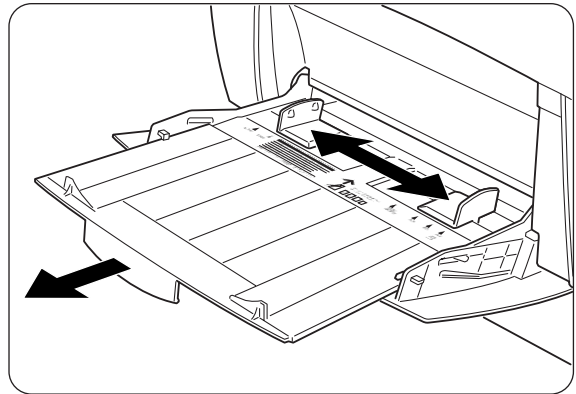

2. Fan a few transparency sheets at a time.

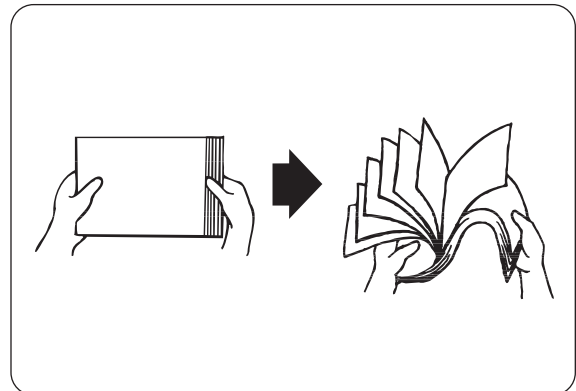

3. Insert the transparency sheets into the multi-purpose tray until they lightly touch the feeding slot.

Look

Do not use full color transparency sheets. They can jam in the printer and damage the fuser unit.

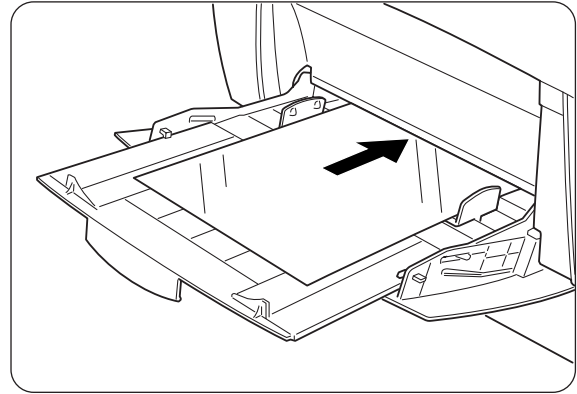

4. Launch printing from your program after loading the transparency sheets in the printer. Now set the items for “Printer Driver Settings (for transparency sheets)” as shown below:

❖ **Printer Driver Settings (for transparency sheets)**

Windows settings

Tab	Item	Setting
Paper/Output	Paper Size	A4 or Same as Document Size (When the document size is A4)
	Duplex	OFF
	Paper Tray	MP Tray
	Paper Type	Transparency

Macintosh settings

Dialog Box	Item	Setting
Paper Settings	Paper Size	A4 or no change (When paper size is A4)
	Paper Type	Transparency
General Settings	Document Type	Transparencies
Printer Settings	Duplex	OFF
	Paper Tray	MP Tray

⇒ Note

You can also print transparency sheets with paper inserted between the sheets. For details about the way to set paper between the sheets and the functions of individual printer driver items, refer to Help. For details about how to use Help, refer to 3.4 “Using Help”.

3.7.3 Printing Custom-size Paper

Using the multi-purpose tray enables you to print custom-size paper or 'long' paper, longer than legal portrait (355.6 mm (14 in.)).

The paper sizes suitable for use with this printer are as follows:

- Single-sided printing: Width 90-216 mm (3.5 – 8.5 in.); Length 139.7-900.0 mm (5.5 – 35.4 in.)
- Duplex printing: Width 90-216 mm (3.5 – 8.5 in.); Length 139.7-355.6 mm (5.5 – 14 in.)

Look

Feeding custom-size paper sidewise is not possible. Always feed this type of paper lengthwise.

To print on custom-size paper, you must set the paper size as a user defined size first.

❖ **Setting a User Defined Size**

With a Macintosh computer, you need to set the user defined size while executing a printing command from a program. Continue to "How to Print".

In Windows, you need to set the user defined size before launching the printing command from a program, using the following procedure: The following example is for Windows 98.

- 1.** On the Start menu, point to Settings and click Printers.
The Printers window opens.
- 2.** Click the appropriate printer and on the File menu, click Properties.
The Properties dialog box opens.
- 3.** Click the Default Settings tab.
- 4.** Click Custom Paper Size.
The Custom Paper Size dialog box appears.

5. Select one of the five paper sizes.

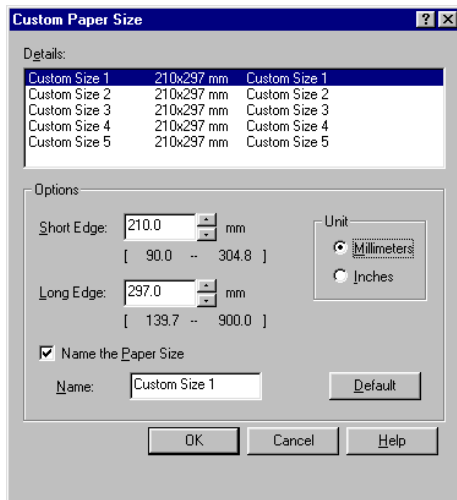

See

For details of the Custom Paper Size dialog box settings, refer to Help. For details about how to use Help, refer to 3.4 “Using Help”.

6. When you finish making the settings, click OK in the Custom Paper Size dialog box.
7. In the Properties dialog box, click OK. The user defined size is now set.

How to Print

Follow the steps below to print on custom-size (long) paper.

1. Adjust the paper guide to the width of the paper that you are about to use.
2. With the printed side facing down, set the paper into the multi-purpose tray so that it lightly touches the feeding slot.
3. Launch printing from your program after setting the paper. Set the items for “Printer Driver Settings (for Custom-size (Long) Paper)” as shown.

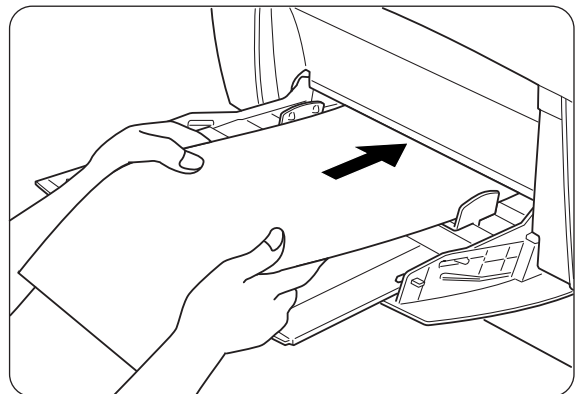

Look

When printing on long paper, after giving the print command, support the paper with your hands while it feeds into the printer.

❖ **Printer Driver Settings (for Custom-size (Long) Paper)**

Windows settings

Tab	Item	Setting
Paper/Output	Paper Size	A paper size selected from Custom Size 1 -Custom Size 5 in the Default Settings tab in the printer driver dialog box.
	Paper Tray	MP Tray

Macintosh settings

Dialog Box	Item	Setting
Paper Settings	Paper/Output	Set the paper size in the Custom Paper Size dialog box in [Page Sizes].
Custom Paper Size	long, short	Set the paper size that you want to use.
Printer Settings	Paper Tray	MP Tray

⇒ Note

For details about individual printer driver items, refer to Help.
For details about how to use Help, refer to 3.4 “Using Help”.

3.8 Duplex Printing

You can perform duplex printing with the printer, using one of the following procedures.

- For plain paper, whether fed from a paper tray or the multi-purpose tray, duplex printing is carried out automatically if you set this in the printer driver upon executing the print command.
- For specialty paper such as cards or cardboard, you can print on the back surface of the paper from the multi-purpose tray as long as the front surface of the paper was printed using this printer.

See

For details about the types of paper suitable for duplex printing, refer to 4.1.1 “Suitable Paper Types”.

Note

When performing duplex printing frequently in Windows, we recommend that you register the necessary settings in the User Settings tab. Registering the settings saves you time, because you do not need to configure the driver each time you print. For details about the User Settings tab, refer to Help.

Types of Duplex Printing

There are two types of duplex printing: “long binding” and “short binding”. The results of printing with the two types are shown below:

<Long Edge Binding>

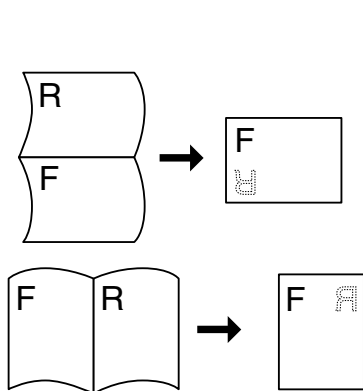

<Short Edge Binding>

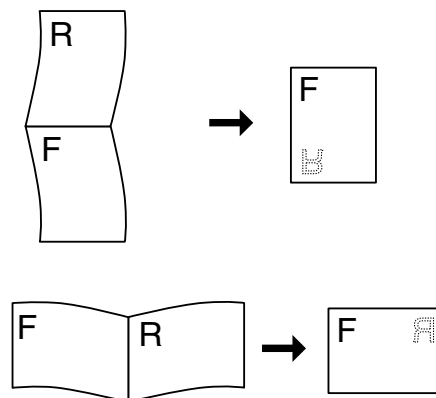

3.8.1 Duplex Printing

To print on both sides of plain paper, set the paper into the paper tray or multi-purpose tray.

Follow the procedure below to print on both sides of plain paper.

1. Set the paper lengthwise into the paper tray or multi-purpose tray.

Look

When printing on both sides of custom-size plain paper (width: 90-216 mm (3.5-8.5 in.); length: 139.7-355.6 mm (5.5-14 in.)), print each sheet from the multi-purpose tray one at a time.

2. Launch printing from your program after setting the paper. Now set the items for “Printer Driver Settings (for duplex printing on plain paper)” as shown below:

Printer Driver Settings **(for duplex printing on plain paper)**

Windows settings

Tab	Item	Setting
Paper/Output	Duplex Print	Long Edge Binding or Short Edge Binding
	Paper Type	Plain Paper 1 or Plain Paper 2

Macintosh settings

Dialog Box	Item	Setting
Paper Settings	Paper Type	Plain Paper 1 or Plain Paper 2
Printer Settings	Duplex Print	Long Edge Binding or Short Edge Binding

Note

With custom sizes, it is necessary to configure other items to suit the paper size. Refer to the previous section or the printer driver Help for details about these settings. For details about how to use Help, refer to 3.4 “Using Help”.

When printing on the back of specialty paper, make sure that you configure the items below in the printer driver when giving the print command from the program.

❖ **Printer Driver Settings** **(for printing the back side of specialty paper)**

Windows settings

Tab	Item	Setting
Paper/Output	Paper Tray	MP Tray
	Paper Type	Thick Paper 1, Thick Paper 2 or Glossy Paper

Macintosh settings

Dialog Box	Item	Setting
Paper Settings	Paper Type	Thick Paper 1, Thick Paper 2 or Glossy Paper
Printer Settings	Paper Tray	MP Tray

⇒ Note

With custom sizes, it is necessary to configure other items to suit the paper size. Refer to the previous section or the printer driver Help for details about these settings. For details about how to use Help, refer to 3.4 “Using Help”.

CHAPTER 4

LOADING PAPER AND USABLE PAPER TYPES

4.1 Suitable and Unsuitable Paper Types

Using paper that is unsuitable for printing can cause paper jams and deteriorate print quality. We recommend that you use the types of paper listed below for the best results from your printer.

4.1.1 Suitable Paper Types

❖ Suitable Basis Weight

When using stationary supplier paper, make sure that it complies with the following specifications. However, we recommend that you use standard domestic paper.

Feeding Method	Specifications
Multi-purpose Tray (MP Tray)	Basis weight: 60 to 216 g/m ² (16.0 to 57.5 lb)
Standard Paper Tray (tray1) Trays 2, 3 (optional tray module)	Basis weight: 60 to 105 g/m ² (16.0 to 28.0 lb)

⇒ Note

“Basis weight” refers to the weight of one square meter of paper.

❖ Recommended Paper

Recommended paper for this printer is defined as follows:

Paper Type	Europe	USA
Plain paper	Xerox Premier 80 g/m ² (21.3 lb) Xerox Business 80 g/m ² (21.3 lb) Modo DATACOPY 80 g/m ² (21.3 lb) IGEPA X-Press 80 g/m ² (21.3 lb)	Xerox 4200DP 20 lb Champion Paper One 20 lb Hammermill Laser Paper 24 lb
Recycled paper	Steinbis Recycling Copy 80 g/m ²	—
Transparency	3M CG3300	3M CG 3300
Label	Avery laser label L7163	Avery laser label #5160

❖ Special paper

You can print the following types of paper from the multi-purpose tray. They are referred to as 'specialty paper'.



Paper Type	Important
Transparency sheets	Do not use full color transparency sheets (bordered by a white frame).
Label sheets	Use label sheets that are uncut with labels covering the whole sheet.
Envelopes <ul style="list-style-type: none"> • Com-10 • Monarch • C5 • DL 	Do not use envelopes that have tape seals. Printing some types of preglued envelopes may not be possible, depending on the condition of the adhesive. We recommend using envelopes designed for <i>laser</i> printers.
Cardboard Basis weight: 100 to 216 g/m ² (26.6 to 57.5 lb)	When printing on rigid cardboard, the image position may shift.
Coated paper	When printing on coated paper, feed the sheets one by one. Moisture can cause the sheets to stick together, causing more than one sheet go through at one time, which can result in malfunction or damage.

◆ **PANTONE® Calibrated**

There are many variables in the process for reproducing color generated by the HL-4000CN, any one of which may affect the quality of the PANTONE Color simulation including type of paper used, type of toner used, effective final resolution and dot structure/halftones. For optimal results, we recommend that the NEUSIEDLER Color Copy 90 g/m² (24.0 lb) and genuine Brother toner cartridge and Pantone Mode setting (only for PostScript driver.)

❖ Paper Trays, Types, and Sizes

The paper types, sizes, and the maximum number of sheets that you can load in the different trays are shown in the table below. Load all paper into the printer in the portrait orientation (lengthwise).

Feeding Method	Paper Type	Maximum number of sheets	Paper Sizes
Multi-purpose Tray	Plain paper 1 (60 to 75 g/m ² / 16.0 to 20.0 lb) Plain paper 2 (76 to 99 g/m ² / 20.2 to 26.3 lb) envelopes, label sheets, Transparency film (monochrome), Cardboard 1 (100 to 159 g/m ² / 26.6 to 42.3 lb), Cardboard 2 (160 to 216g/m ² / 20.2 to 26.3 lb)	Up to 150 sheets or a 10-mm (0.4 in.) stack	A5 B5 A4 8.5 x 11" (Letter) 8.5 x 14" (Legal) Envelopes (Com-10, Monarch, C5, DL) User-defined size (width: 88.9 to 215.9 mm (3.5 to 8.5 in.), length: 139.7 to 900 mm (5.5 to 35.4 in.)) Important  Look <hr/> <ul style="list-style-type: none">Using low-quality paper can cause creasing and deteriorate print quality.When printing on paper longer than 355.6 mm (14 in.), support the paper with your hands while it feeds through the printer. <hr/>
	Coated paper Paper longer than 355.6 mm (14 in.)	1 sheet	
Standard Paper Tray (tray1)	Plain paper 1 (60 to 75 g/m ²) Plain paper 2 (76 to 99 g/m ²)	Up to 500 sheets or a 56-mm (2.2 in.) stack  Look <hr/> For A5 portrait, you can use up to 350 sheets or a 40-mm (1.6 in.) stack. <hr/>	A5, B5, A4, 8.5 × 11" (Letter), 8.5 × 14" (Legal)
Trays 2, 3 Tray module (2 shelves) (Trays 2 and 3)			

Look

The number of sheets that you can load varies according to paper thickness.

⇒ **Note**

The illustrations below provide a description of 'width' and 'length' mentioned in the table above.

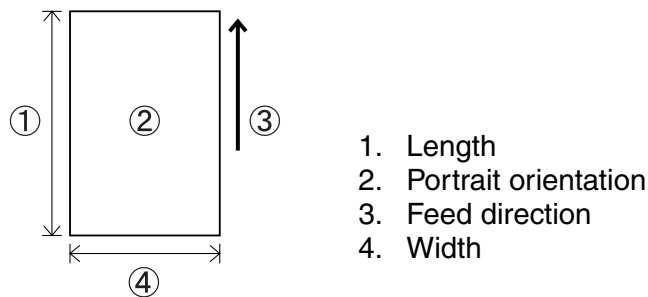

❖ Duplex Printing Paper Types and Sizes

You can print on both sides a sheet of paper with the printer.

Automatic Duplex Printing

For automatic duplex printing, select Duplex in the printer properties after executing the print command.

You can use the following paper types and sizes for duplex printing:

Paper Type	Paper Sizes
Plain Paper (Basis weight: 60 to 99 g/m ² (16.0 to 26.3 lb))	A5 B5 A4 8.5 × 11" (Letter) 8.5 × 14" (Legal)

Manual Duplex Printing with the Multi-purpose Tray

To print on both sides of the following types of specialty paper, print the front face first, then load the sheets into the multi-purpose tray to print the back face.

👉 **Look**

Do not print the back face of sheets whose front face was printed using a printer other than this printer.

Paper Type
Cardboard (Basis weight: 100 to 216 g/m ² (26.6 to 57.5 lb)) Envelopes Coated paper

4.1.2 Unsuitable Paper Types

Avoid using the following paper types as they can cause paper jams or damage the printer.

- Transparency sheets other than those recommended.
- Inkjet paper
- Paper that is too thick or too thin
- Paper with a face preprinted with another printer or copier, or paper preprinted with ink
- Folded, creased, or torn paper
- Damp or wet paper
- Curled or warped paper
- Sheets affected by static electricity
- Layered or adhesive paper
- Specially coated paper
- Colored paper with a treated surface
- Paper printed with ink that cannot withstand temperatures of 155°C (311°F).
- Heat-sensitive paper
- Carbon paper
- Paper with a rough surface such as textured or fiber form paper
- Acidic paper that can cause the characters to fade over time. Use neutral paper.
- Envelopes with a rough surface or clips attached
- Paper with staples, paper clips, tape, or ribbons attached
- Envelopes with sticky adhesive
- Label sheets where the backing is visible or is precut.

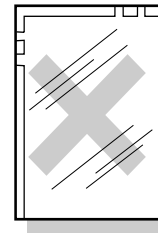

Full color
transparency sheets

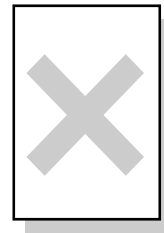

Inkjet paper



Curled paper

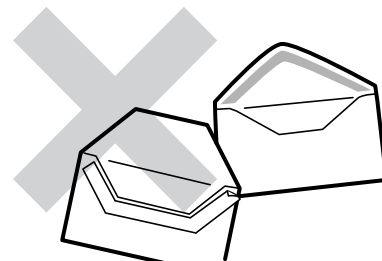

Paper with tape attached

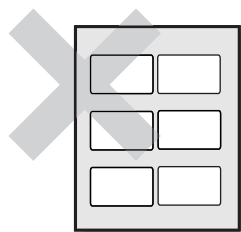

Shiny backing paper visible

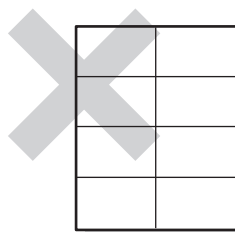

Precut label sheets

- T-shirt transfer paper (Heat press use)
- Transfer paper (cold water use)
- Digital coated glossy paper
- Label film (transparent, colorless)
- Perforated paper

4.1.3 Storing Paper

Failure to properly store paper can cause paper jams, deteriorate print quality, or damage the printer. Store paper under the following conditions:

- Between 10°C and 30°C (50 to 86°F)
- Between 30% and 65% relative humidity
- In a dry place
- After opening the package, wrap unused sheets in their original package and store in a cabinet or other dry place.
- Store paper on a flat surface. Do not lean paper against other objects or place it in an upright position.
- Avoid storing paper in a way that may cause creasing, folding, or curling.
- Store paper away from direct sunlight.

4.2 Loading Paper

Refer to the appropriate section below to load or change paper.

 **See**

For more information about suitable paper types, refer to 4.1 “Suitable and Unsuitable Paper Types”.

4.2.1 Load Paper in the Paper Tray

Follow the procedure below to load paper into the paper tray.

⇒ Note

Load paper into the optional 2 Tray Module the same way.

To load A5 paper or change to a paper size other than A5, you need to install or remove the A5 spacer. To install or remove the A5 spacer, refer to 4.2.2 “Load A5 Paper in the Paper Tray/Changing the Paper Size from A5”.

1. Gently pull out the paper tray until it stops.

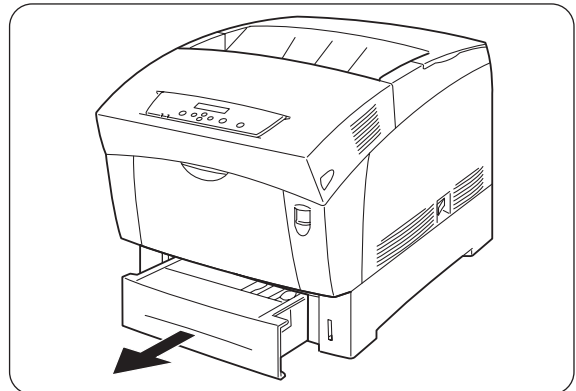

2. Hold the tray with both hands, lift the front slightly and pull it completely out of the printer.

⇒ Note

Place the tray on a flat surface.

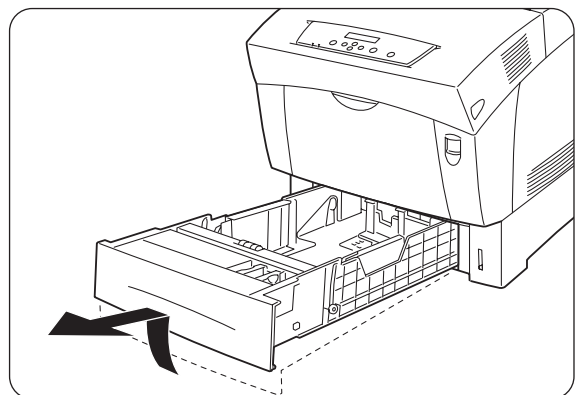

3. Move the side paper guides to their outermost positions.

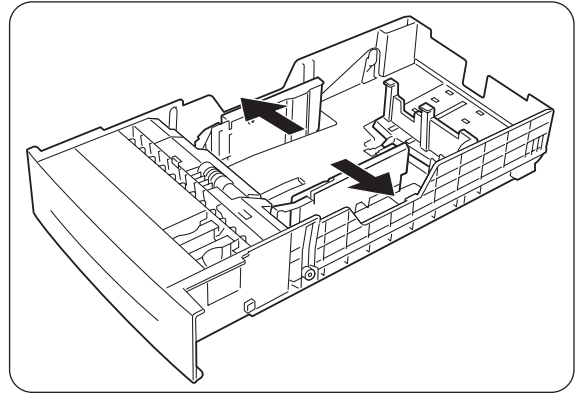

4. Gently lift the end paper guide to move it, and insert the pins at the bottom of the guide in the holes (indicated by the ► mark) corresponding to the paper size that you want to load. Make sure that the end guide is properly inserted into the appropriate holes for the paper size.

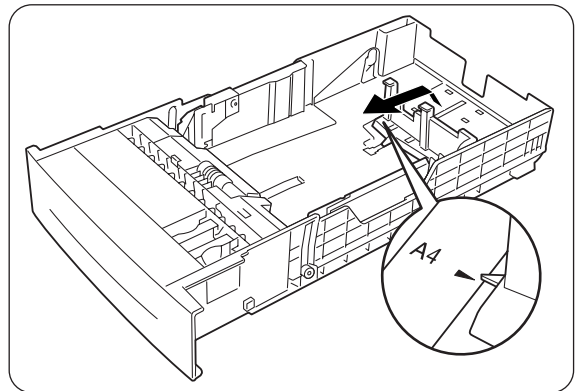

Look

Only a small amount of movement of the end paper guide can make automatic paper size detection impossible. If this occurs, move the end paper guide all the way to its outermost position again, then realign it with the appropriate paper size mark.

5. Align the four corners of the paper stack and insert the paper (print side up) under the tab.

Look

- Do not use paper that is folded, creased, or heavily warped.
- Make sure that all the paper is under the tab.
- Do not overload the paper tray.

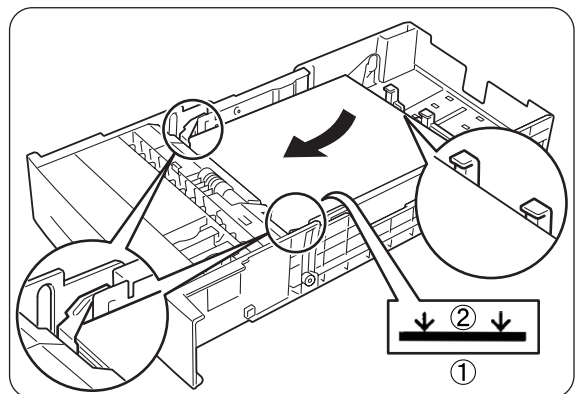

1. Tab
2. MAX loading limit

6. Align the side guides with the edges of the paper.

Look

Pushing the paper guides too hard against the edges of the paper stack can cause a paper jam. However, if the paper guides are too loose, the paper may twist as it feeds through the printer.

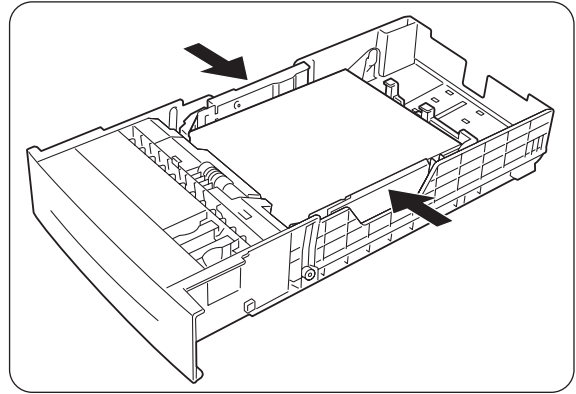

7. Hold the paper tray with both hands, align it with the opening in the printer and gently insert it.

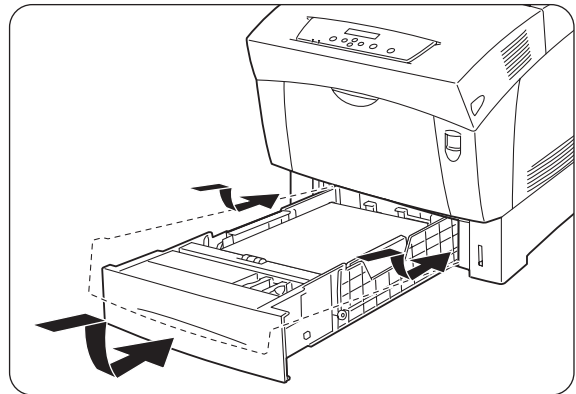

8. Push the paper tray completely back into the printer.

Look

Do not use excessive force on the paper tray. Doing so could damage the paper tray or the inside of the printer.

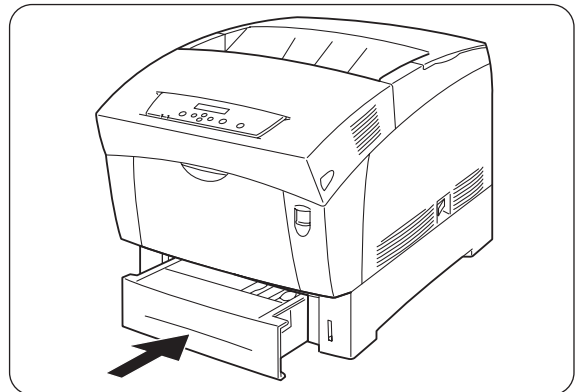

Note

There is an indicator next to the paper tray that tells you how much paper remains in the tray. Use this meter as a guide to refill the paper tray.

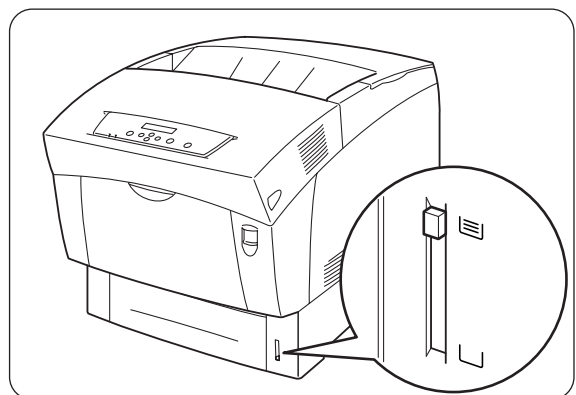

- 9.** When printing A4 or Letter size paper, lift the stopper on the top cover.

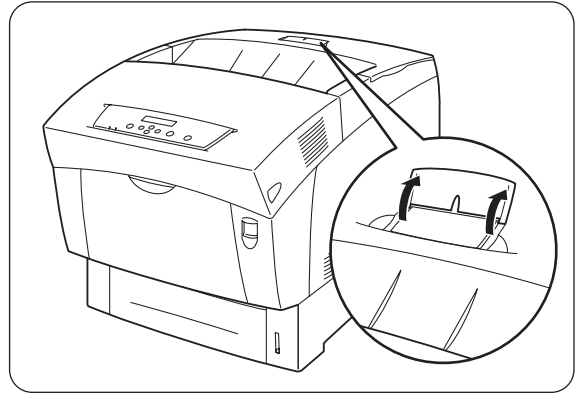

4.2.2 Load A5 Paper in the Paper Tray/Changing the Paper Size from A5

❖ Loading A5 Paper

Follow the procedure below to load A5 paper into the paper tray.

⇒ **Note**

Load paper into the optional 2 Tray Module the same way.

1. Gently pull out the paper tray until it stops.

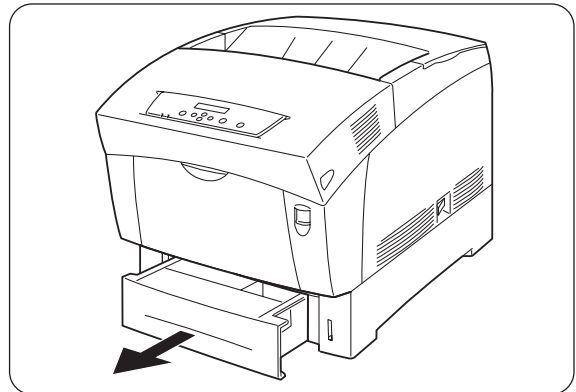

2. Hold the tray with both hands, lift the front slightly and pull it completely out of the printer.

⇒ **Note**

Place the tray on a flat surface.

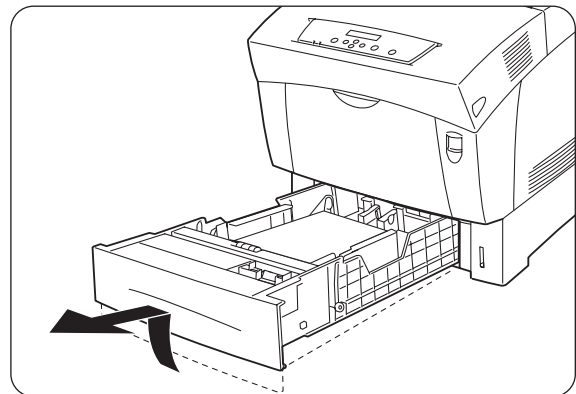

3. Move the side paper guides to their outermost positions.

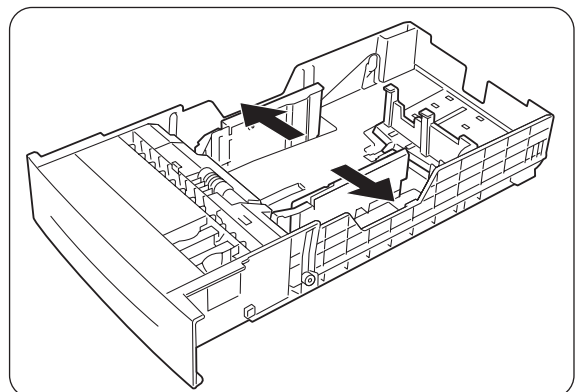

4. Gently lift the end paper guide to move it, and insert the pins at the bottom of the guide in the holes (indicated by the ► mark) corresponding to the paper size that you want to load. Make sure that the end guide is properly inserted into the appropriate holes for the paper size.

👉 **Look**

Only a small amount of movement of the end paper guide can make automatic paper size detection impossible. If this occurs, move the end paper guide all the way to its outermost position again, then realign it with the appropriate paper size mark.

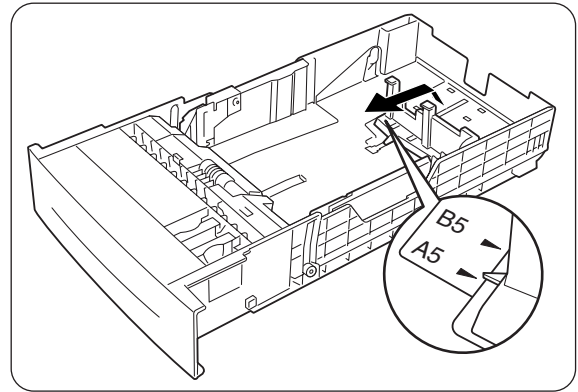

5. Grip the A5 spacer, gently lift it up while pulling it forward and remove it from the tray.

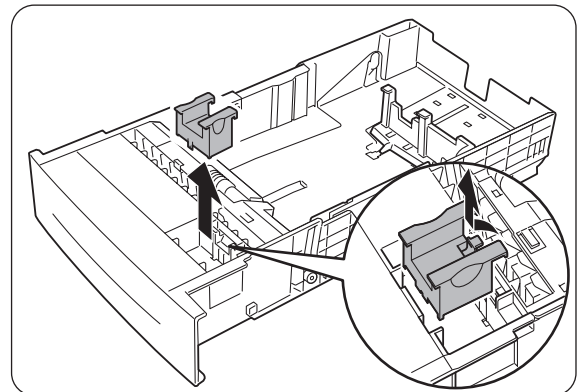

6. Align the A5 spacer with the paper guide slot and push it down until it clicks.

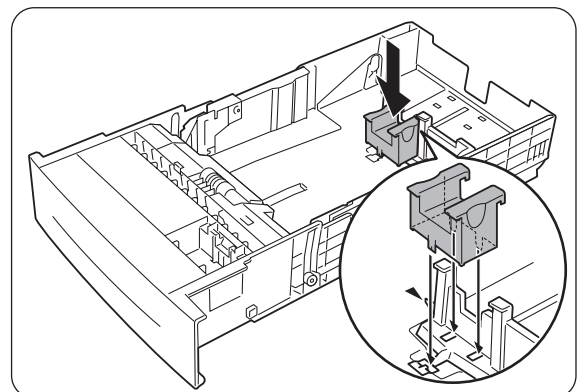

7. Align the four corners of the paper stack and insert the paper (print side up) under the tab.

 **Look**

- Do not use paper that is folded, creased, or heavily warped.
- Make sure that all the paper is under the tab.
- Do not overload the paper tray.

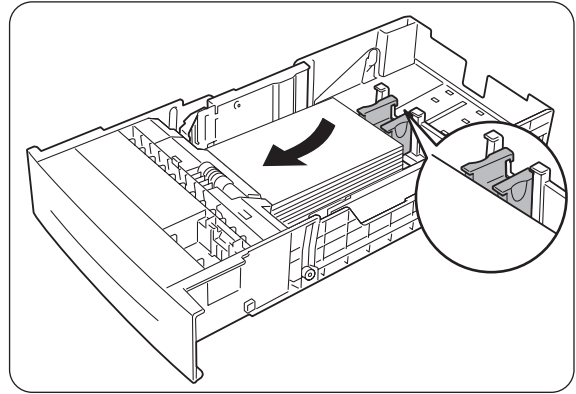

8. Align the side guides with the edges of the paper.

 **Look**

Pushing the paper guides too hard against the edges of the paper stack can cause a paper jam. However, if the paper guides are too loose, the paper may twist as it feeds through the printer.

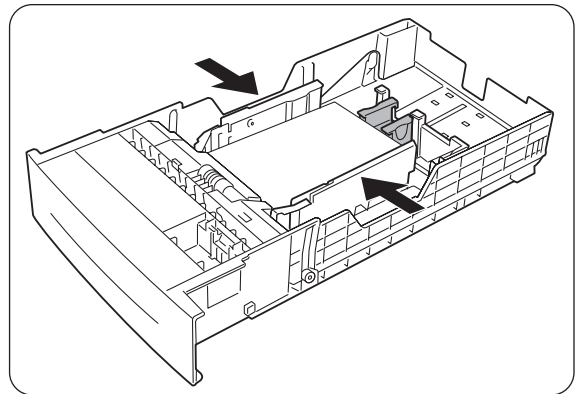

9. Hold the paper tray with both hands, align it with the opening in the printer and gently insert it.

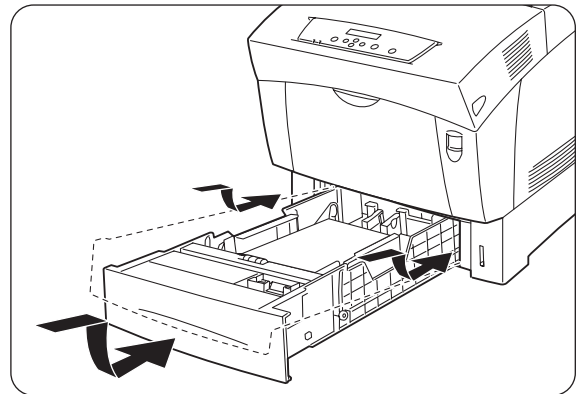

10. Push the paper tray completely back into the printer.

 **Look**

Do NOT use excessive force on the paper tray. Doing so could damage the paper tray or the inside of the printer.

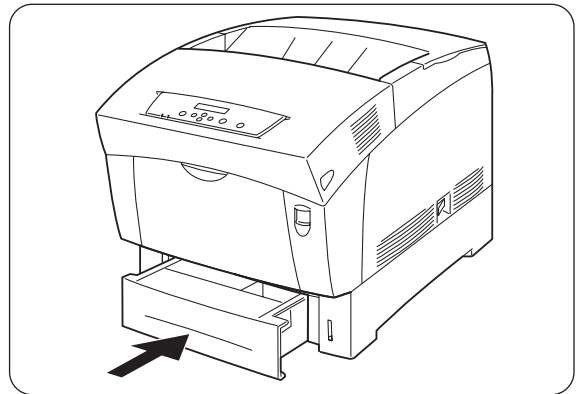

⇒ **Note**

An indicator next to the paper tray tells you how much paper remains in the tray. Use this meter as a guide to refill the paper tray.

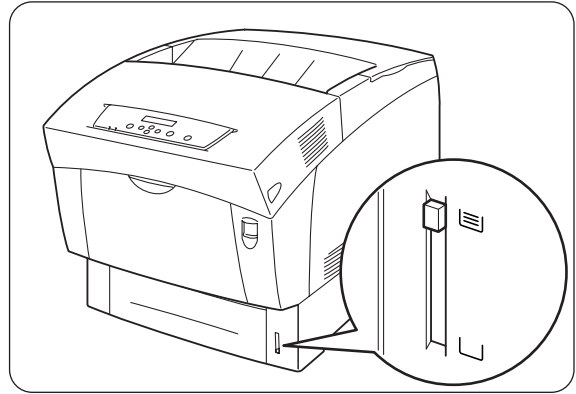

❖ **Changing the Paper Size from A5**

Follow the procedure below to remove the A5 spacer and load a different paper size into the paper tray.

⇒ **Note**

Load paper into the optional 2 Tray Module the same way.

1. Gently pull out the paper tray until it stops.

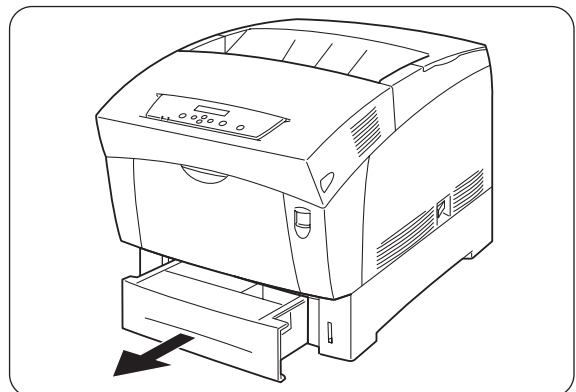

2. Hold the tray with both hands, lift the front slightly and pull it completely out of the printer.

⇒ **Note**

Place the tray on a flat surface.

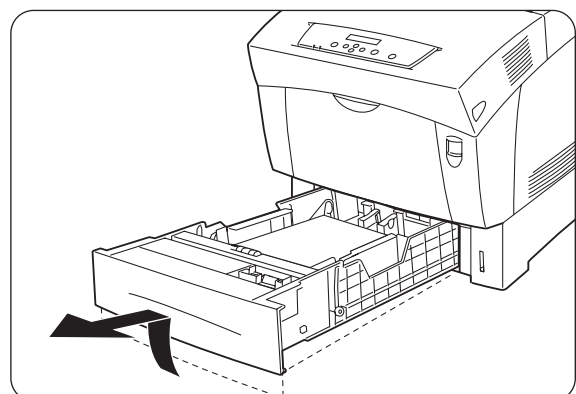

- 3.** Move the side guides to their outermost positions and remove the paper from the tray.

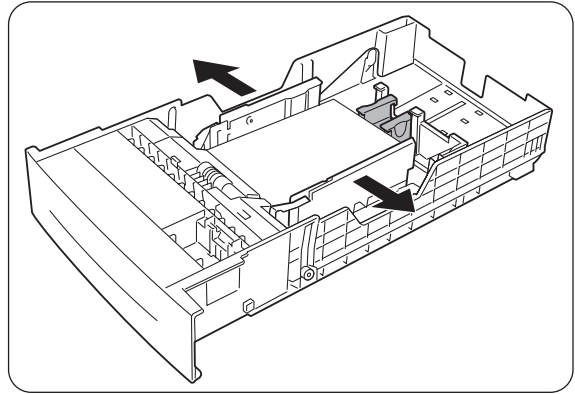

- 4.** Grip the A5 spacer, gently lift it up while pulling it forward and remove it from its position next to the paper guide.

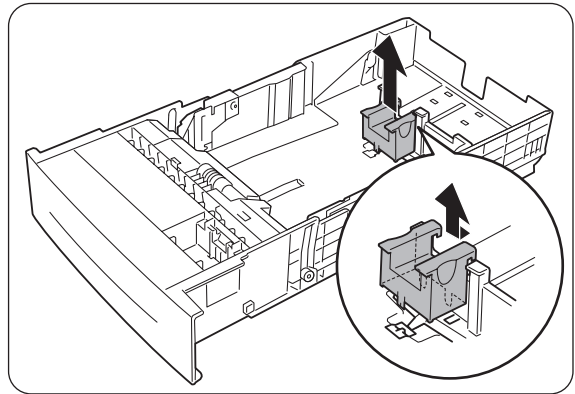

- 5.** Insert the A5 spacer into its storage slot in the paper tray.

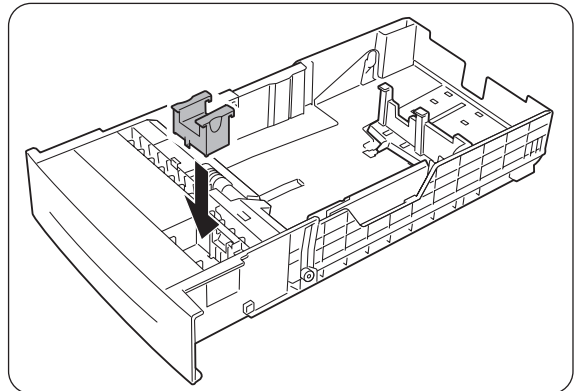

6. Gently lift the end paper guide to move it, and insert the pins at the bottom of the guide in the holes (indicated by the ► mark) corresponding to the paper size that you want to load. Make sure that the end guide is properly inserted into the holes for the paper size.

👉 **Look**

Only a small amount of movement of the end paper guide can make automatic paper size detection impossible. If this occurs, move the end paper guide all the way to its outermost position again, then realign it with the appropriate paper size mark.

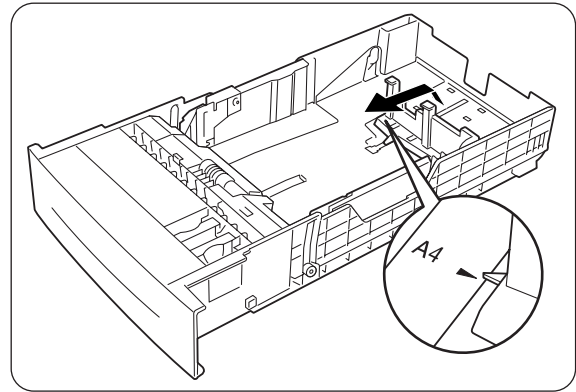

7. Align the four corners of the paper stack and insert the paper (print side up) under the tab.

👉 **Look**

- Do not use paper that is folded, creased, or heavily warped.
- Make sure that all the paper is under the tab.
- Do not overload the paper tray.

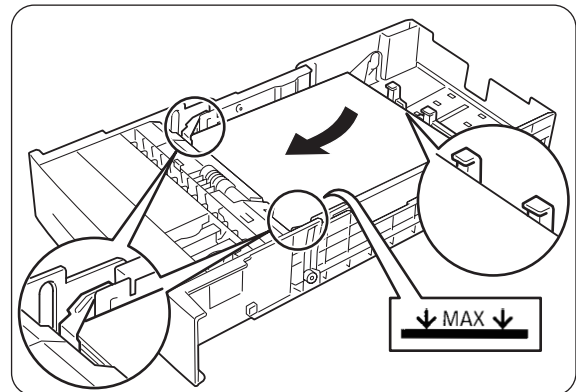

8. Align the side guides with the edges of the paper.

👉 **Look**

Pushing the paper guides too hard against the edges of the paper stack can cause a paper jam. However, if the paper guides are too loose, the paper may twist as it feeds through the printer.

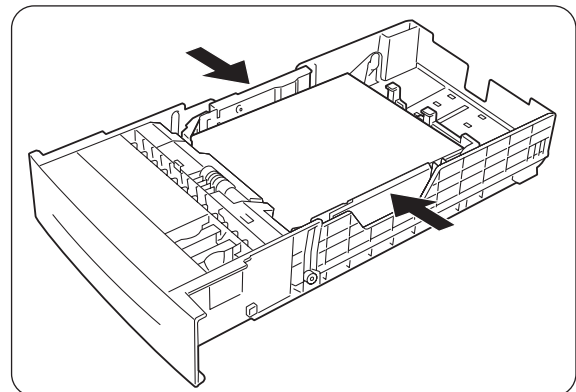

- 9.** Hold the paper tray with both hands, align it with the opening in the printer and gently insert it.

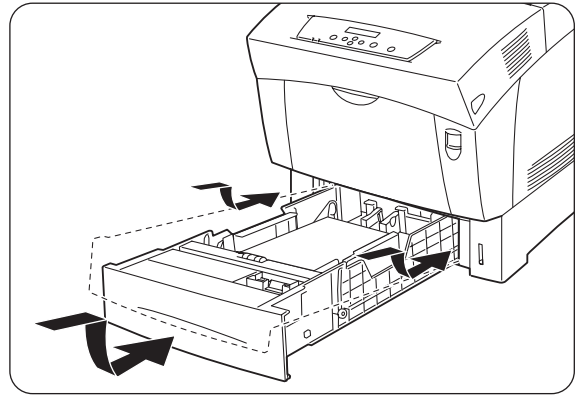

- 10.** Push the paper tray completely back into the printer.

Look

Do not use excessive force on the paper tray. Doing so could damage the paper tray or the inside of the printer.

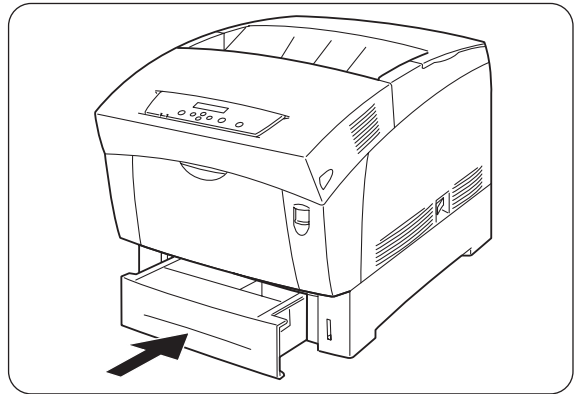

Note

There is an indicator next to the paper tray that tells you how much paper remains in the tray. Use this meter as a guide to refill the paper tray.

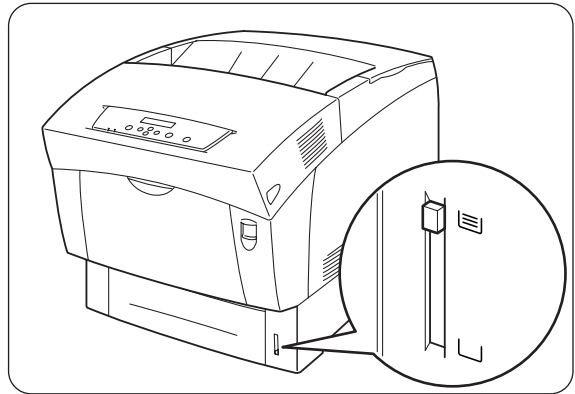

- 11.** When printing A4 or Letter size paper, lift the stopper on the top cover.

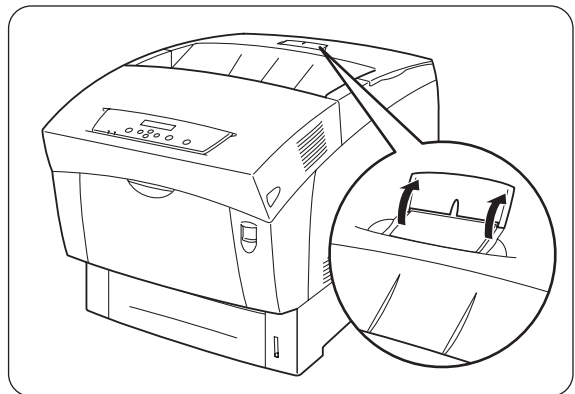

4.2.3 Load Paper into the Multi-purpose Tray

Follow the procedure below to load paper into the multi-purpose tray.

Look

To avoid paper jams, do not load paper of different sizes into the tray at the same time and do not refill the multi-purpose tray before it is empty.

1. If retracted, open the tray.

Look

To avoid damage to the tray, do not use excessive force or place heavy objects on the tray.

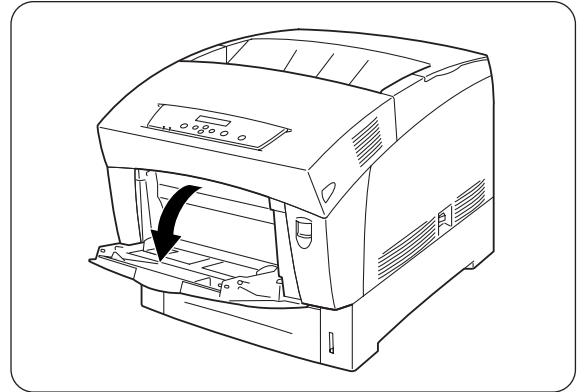

2. Adjust the paper guide to the mark corresponding to the size that you are about to use.

Look

When printing on long paper, pull out the tray extension. Printing long paper with the tray extension retracted can cause the paper to fall or make feeding impossible.

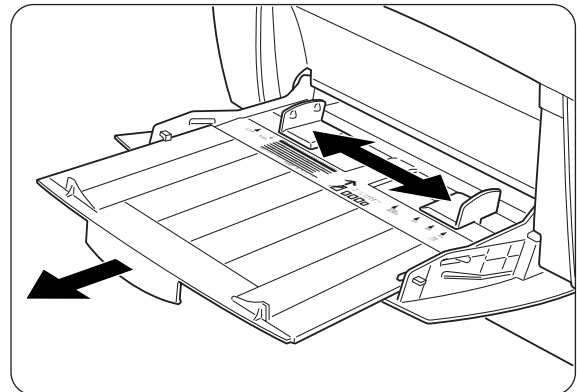

3. When using media such as transparency sheets, label sheets, or envelopes, fan the stack before loading so that there is air between the sheets.

Note

Fanning the stack helps prevent paper jams.

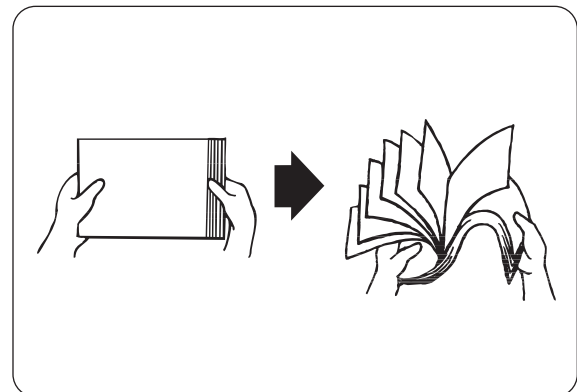

Look

- Do not fan plain paper before loading.
- When paper is poorly cut and the edges are not clean, remove any unsuitable sheets before loading the paper.

4. Align the four corners of the paper stack and insert it (print side down) until it lightly touches the feeding slot.

Look

- Do not use paper that is folded, creased, or heavily warped.
- Do not overload the paper tray.
- When printing on sheets longer than Legal paper (355.6 mm (14 in.)), load the sheets one by one. Moisture can cause the sheets to stick together, causing more than one sheet go through at one time, which can result in malfunction or damage. When feeding long paper, support the sheet with your hands to ensure proper feeding.

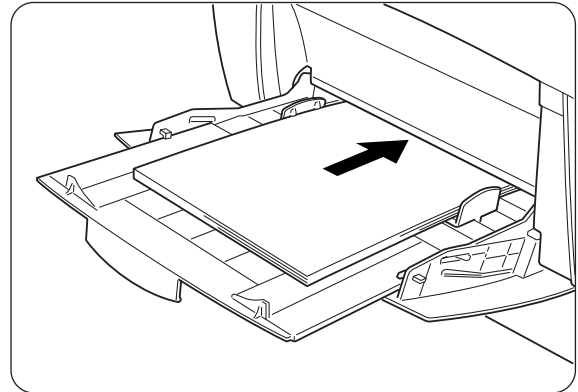

5. When loading paper, carefully align the paper guides with the edges of the paper so that there is a small gap between the paper stack and the guides. Pushing the paper guides too hard against the edge of the paper stack can warp the paper and cause paper jams. Load the paper so that it is straight in the tray.

Look

If the paper is not loaded correctly, the printing position may shift and cause incorrect printing.

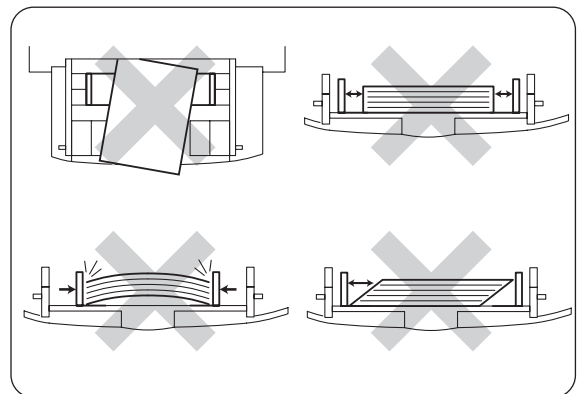

CHAPTER 5

CONTROL PANEL

5.1 Control Panel Functionality

The control panel consists of LED indicators, a display and several buttons. This section describes the names and functions of the control panel.

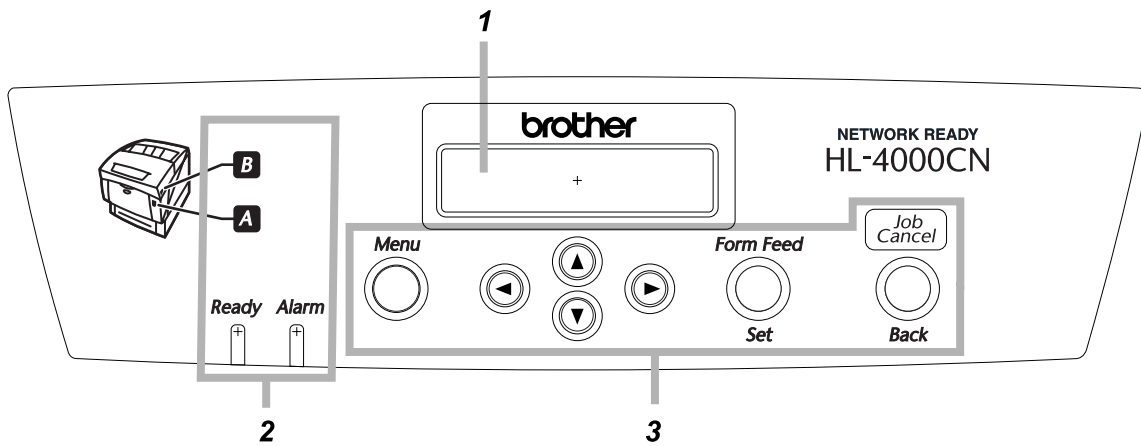

1. Display
2. LED indicators
3. Buttons

5.1.1 LED Indicators

Refer to the following table to establish the printer status.

Name	Description
Ready indicator	Green. Indicates printing status. On : Indicates that the printer is not receiving data or that it is ready to print. Flashing : The printer is receiving print data. Off : Printing is not possible.
Alarm indicator	Red. Indicates an error. On : Indicates a paper jam or some other problem that the user can rectify. Flashing : There is a problem that the user cannot rectify. Contact your dealer or Brother authorized service representative. Off : The printer is functioning normally.
Cover Open indicator	Indicates what buttons to press to open the front cover to clear paper jams. On : Press the button indicated and open the front cover. Off : The printer is functioning normally.

5.1.2 Display

Displays printer status (“print screen”) and menus for configuring the printer (“menu screen”).

⇒ **Note**

The items displayed differ depending on printer settings and installed options.

❖ **Print screen**

When the printer is waiting for data or printing, this screen is displayed. The contents of the print screen are as follow.

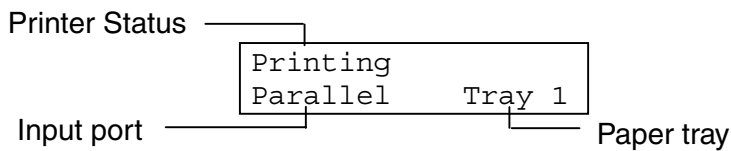

Name	Description
Printer status	Shows the printer status. Example: “Please Wait...”, “Printing”, “Ready to Print”.
Input port	Shows the port through which the printer is receiving data. Example: “Parallel”, “USB”, “LPD”, “NetWare”, “AppleTalk”.
Paper tray	Shows the paper tray in use. Example: “Tray 1”, “Tray 2”, “Tray 3”, “MP Tray”.

❖ **Menu screen**

Use this screen to configure the printer.

The menu screen appears when you press the Menu button. The first screen displayed contains the following:

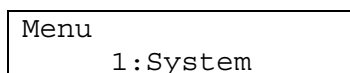

See

For details about the menu screen, refer to 5.2 “Basic Menu Operation”.

5.1.3 Buttons

There are 7 buttons on the control panel.

The functions depend on the screen displayed. Their functions are as follows:

Name	Print screen	Menu screen
Menu button	Switches to the menu screen.	Closes the menu screen and switches to the print screen.
< ▲ >< ▼ > Buttons	-	Allows you to scroll through menus and menu items.
< ◀ ▶ > Buttons	-	Switches to different menu levels and move the cursor between parameters. Pressing the < ▶ > button once in a menu moves the menu one level down. Pressing the < ◀ > button moves the menu one level up.
<Form Feed/Set> button	Forces the remaining print data to be output. For details about this function, refer to 6.9 "Forcing the Printer to Print Remaining Data (When Printing is Halted)"	Selects menus and menu items. Moves the menu one level down when a menu is selected. Sets a parameter when one is displayed.
<Job Cancel/Back> button	Cancels printing. For details about this function, refer to 3.5 "Cancel Printing".	Moves the displayed menu one level up.

5.2 Basic Menu Operation

This section describes how to use the menu screen to set the energy save mode, job timeout, network settings and printer configuration.

5.2.1 Menu Structure and Basic Operations

The menu screen contains the following 5 main menus.

 **See**

For details about individual menu screens, refer to 5.3 “List of Menu Items”.

Menu	Contents
1:System	Use this menu to configure the energy save mode, job log settings, and basic printer operation.
2:Maintenance	Use this menu to reset NV memory to its defaults, adjust paper quality to plain paper, and set access restrictions to certain menus.
3:Parallel	Use this menu to configure the parallel interface.
4:Report/List	Use this menu to print the printer configuration list, panel settings list, PCL6 font list, and print log.
5:Network	Use this menu to change network settings.
6:USB	Use this menu to change the Adobe Protocol settings.

Please note that each menu has several levels. Configure the printer by selecting the different levels and setting the items therein.

Resetting the printer settings

Example: Reset the Job Timeout setting to the default

Press the <▲> and <▼> buttons simultaneously.

Job Timeout
_sec.



1. Press the <▲> and <▼> buttons simultaneously. The following screen appears.

Setting reset
to defaults



When processing finishes, the default settings appear.

Job Timeout
30sec.



2. Press the <Form Feed/Set> button. The parameters are now set.

Job Timeout
30sec.*

5.2.2 What to do if you make a Mistake?

Perform the appropriate operation below if you accidentally press a wrong button while using the control panel.

You accidentally pressed the <Form Feed/Set> button, but you want to return to the preceding screen.

Press the <Job Cancel/Back> or < ◀ > button.

You accidentally pressed the < ▼ > button, but you want to return to the preceding screen.

Press the < ▲ > button.

You made a mistake and cannot display the preceding screen.

Press the menu button and remake the settings.

You accidentally pressed the <Form Feed/Set> button and set the wrong parameter.

When the parameter is set, '*' appears next to it.

When '*' appears next to a parameter, pressing the <Job Cancel/Back> or the < ◀ > button does not return to the preceding screen. Remake that particular setting.

5.3 *List of Menu Items*

The section describes the various modifiable items of each main menu.

Look

It is possible to set some items of the menu screens from your computer when you print. If the computer settings differ from those on the printer, the computer settings take precedence.

Note

'Default' refers to the factory settings of the printer.

5.3.1 *System Settings*

Used to configure the energy save mode, job log settings, and basic printer operation.

Power Save Time

Energy save mode reduces the electricity consumption of the printer when it is idle. Mode 1 partially reduces the power consumption of certain parts of the printer. When the printer is in energy save mode 1, 'Ready/Standby' appears on the display. When in this state, the printer takes slightly more time than usual to start printing when it receives data.

The table below describes the situations where the printer will stop being in energy save mode:

Release from Energy Save Mode 1
<ul style="list-style-type: none">• When receiving print data.• When printing a report or list with '4 Report/List'.

- Mode 1 timeout (default: 3 minutes)
Set a time between 1 and 120 minutes. The printer automatically goes into energy save mode 1 when it is idle for the duration you set here.

Error Alarm

This allows you control if the printer sounds an audible alarm when an error occurs.

Note

It is not possible to adjust the volume of the alarm.

❖ **Job Timeout**

The job timeout function causes the printer to stop processing print data when it takes more than a certain amount of time for the remaining data to be received by the printer. When a job timeout occurs, the printer only prints the data it received up to the timeout.

- 5 to 300 seconds (default: 30 seconds)
Set the job timeout between 5 and 300 seconds.
- OFF
Deactivates the job timeout function.

❖ **Panel Language**

Use this to set what language appears on the control panel.

❖ **Auto Log Print**

Set this to print logs automatically.

Look

You cannot change this setting while the printer is processing print data.

Note

Use the '4 Report/List' menu to print logs.

- No (default)
The printer does not print logs automatically.
- Yes
The printer automatically prints a log after 22 print jobs.

❖ **ID Print**

Use this to print the user ID in a particular location.

- OFF (default)
- Upper Left
- Upper Right
- Lower Left
- Lower Right

❖ **Text Print**

Setting the option to Yes, will ensure all data will be printed as it is received and any control codes embedded within the document will be ignored. Generally speaking we do not recommend you set this option to Yes.

- Yes
The data is printed as text.
- No (default)
Data is not printed as text.

5.3.2 Maintenance Mode

Use this mode to reset the non-volatile (NV) memory or adjust paper quality settings. You can use this mode to restrict access to certain menus.

❖ **Init NVM**

Resets the printer's non-volatile memory.
The non-volatile memory stores configuration data, even when the printer is off.

Look

You cannot change this setting while the printer is processing print data.

- YES
Resets the printer's non-volatile memory. Resetting the NV memory resets the printer back to its factory (default) settings.

Look

You must restart the printer for this operation to take effect. After configuring items, be sure to restart the printer.

- NO
Does not reset the NV memory and returns to the menu.

❖ **Security**

When necessary, you can set a password to limit access to menus. This helps prevent items from being changed accidentally.

- PanelSetProtect (default: No)
Select 'ON' to set a password.
- Change Password
Set a 4-digit password.

⇒ **Note**

If you forget the password, reset the NV memory, refer to the previous page.

❖ **Basis Weight**

Use this to adjust the paper quality settings.

- Plain paper 1 (default: Light 60-75 g/m² (16.0 to 20.0 lb))
Set plain paper 1 to 'Light 60-75 g/m²' (16.0 to 20.0 lb) or 'Heavy 65-80 g/m²' (17.3 to 21.3 lb).
- Plain paper 2 (default: Light 76-99 g/m² (20.2 to 26.3 lb))
Set plain paper 2 to 'Light 76-99 g/m²' (20.2 to 26.3 lb) or 'Heavy 85-105 g/m²' (22.6 to 28.0 lb).

❖ **ColorRegiCorrect**

Use this to print the color registration adjustment chart. After setting up or moving the printer, print the color registration adjustment chart and adjust the color registration to ensure that colors are correctly aligned when printed.

⇒ **Note**

The color registration chart is printed on A4 or Letter paper. (The requested paper size depends on your country.) Set the A4 or Letter paper lengthwise into the paper tray.

See

For details about this operation, refer to 1.1 "Adjusting Color Registration".

5.3.3 Parallel

Use this to configure the parallel interface.

❖ **ECP**

Use this to configure the ECP communication mode of the parallel interface.

- Enabled (default)
The printer receives data in ECP mode.
- Disabled
The printer does not receive data in ECP mode.

5.3.4 Report/List

Use this to print the various reports and lists.

⇒ **Note**

Reports and lists are printed on A4 or Letter paper. (The requested paper size depends on your country.) Set the A4 or Letter paper lengthwise into the paper tray.

❖ **Printer Settings**

This is a list of the hardware installed and detailed configuration.

See

For an example of the printer configuration list, refer to 8.4.1 “Confirming Printer Configuration and Network Settings”.

❖ **Panel Settings**

This is a detailed list of all the settings in the control panel menus.

❖ **PCL6 Font List**

This is a list of the available PCL6 data fonts.

❖ **Log Print**

This is a detailed list of the processed print jobs (maximum 22). Use this list to confirm that jobs were printed correctly.

See

For an example of the print log, refer to 8.4.2 “Confirming the Print Log”.

5.3.5 Network

Use this to make network settings.

Look

-
- You cannot change this setting while the printer is processing print data.
 - You must restart the printer for settings to take effect. After configuring items, be sure to restart the printer.
-

❖ **Ethernet**

Use this to set Ethernet communication speed and mode.

- Auto (default)
10Base-T Half, 10Base-T Full, 100Base-TX Half, or 100Base-TX Full is selected automatically.
- 10Base/Half
- 10Base/Full
- 100Base/Half
- 100Base/Full

❖ **TCP/IP**

Use this to make TCP/IP settings. This menu contains the following:

- Setup IP Address
Select the how to obtain an IP address. Parameters are as follows:
DHCP (default)
The IP address is obtained from a DHCP server on the network.
Panel
Use this to set the IP address from the control panel.

- IP Address
Use this to set the IP address.
[aaa.bbb.ccc.ddd]
Set aaa, bbb, ccc, and ddd between 0 and 255.
You cannot use the following:

224.xxx.xxx.xxx or 255.xxx.xxx.xxx
127.xxx.xxx.xxx

Look

-
- These settings are ignored when you select DHCP in Setup IP Address. To enable the settings, select 'Panel' in 'Setup IP Address'.
 - Specifying the wrong IP address can affect the entire network. Before setting an IP address, consult your system administrator.
-

- Subnet Mask
Use this to set the subnet mask address.
[aaa.bbb.ccc.ddd]
Use 0, 128, 192, 224, 240, 248, 252, 254, or 255 for aaa, bbb, ccc, and ddd.
- Gateway Address
Use this to set the gateway address.
[aaa.bbb.ccc.ddd]
Set aaa, bbb, ccc, and ddd between 0 and 255.
You cannot use the following:

224.xxx.xxx.xxx or 255.xxx.xxx.xxx
127.xxx.xxx.xxx

IPX Frame Type

Set a frame type when you use the printer in an IPX/SPX (NetWare) environment.

- Auto (default)
Sets the frame type automatically.
- 802.3
Set this to use IEEE 802.3 frame type.
- 802.2
Set this to use IEEE 802.3/802.2 frame types.
- SNAP
Set this to use IEEE 802.3/802.2/SNAP frame types.
- Ethernet-II
Set this to use Ethernet-II frame type.

❖ Protocol

Set 'Enabled' or 'Disabled' for each item activate or deactivate them.

- LPD (default: Enabled)
When using TCP/IP, set LDP to 'Enabled' to print with LPD (LPR) or to 'Disabled' if you do not want to use this feature.
- Port 9100 (default: Enabled)
When using TCP/IP, set Port 9100 to 'Enabled' to print with port 9100 (Raw Data Socket) or to 'Disabled' if you do not want to use this feature.
- IPP (default: Enabled)
When using TCP/IP, set IPP to 'Enabled' to print with IPP (Internet Printing Protocol) or to 'Disabled' if you do not want to use this feature. Available with Windows 2000/XP and Windows Me.
- NetBIOS TCP/IP (default: Enabled)
When using NetBIOS (Windows network) with TCP/IP as the transport protocol, set NetBIOS TCP/IP to 'Enabled' to print using NetBIOS or to 'Disabled' if you do not want to use this feature.
- NetBEUI (default: Enabled)
When using NetBIOS (Windows network) with NetBEUI as the transport protocol, set NetBIOS NetBEUI to 'Enabled' to print using NetBIOS or to 'Disabled' if you do not want to use this feature.
- NetWare (default: Enabled)
NetWare to 'Enabled' to print in a NetWare system or to 'Disabled' if you do not want to use this feature.
- AppleTalk (default: Enabled)
Set AppleTalk to 'Enabled' to print in an AppleTalk system or to 'Disabled' if you do not want to use this feature.

❖ **IP Filter**

Use this to block the reception of data from certain locations.

To block a particular IP address, specify the IP address in 'FilterX Address' (X is a number between 1 and 5) and the subnet mask in 'FilterX Mask' as numbers between 0 and 255. For the set address, select 'OFF' (default), 'Reject', or 'Accept' from 'FilterX Mode'.

You can filter up to 5 addresses. Filter1 takes priority over the other filters. Therefore, when setting filters for a number of addresses, assign the addresses in ascending ranges from Filter1 to Filter5.

See

-
- You can also set IP filter settings by connecting to the printer using a web browser or by using the BRAdmin Professional software. For a detailed examples of these settings, refer to the "Network Use's Guide" on the provided CD-ROM.
 - For more information about Web Based Management, refer to 8.5 "Confirming Printer Status from Your Computer".
-

❖ **Init NVM**

This resets the non-volatile memory of the network card (also known as a print server).

Look

You cannot change this setting while the printer is processing print data.

- YES
Resets the memory card's non-volatile memory. Resetting the NV memory restores the items of the '5 Network' menu to their defaults.

Look

You must restart the printer for this setting to take effect. After configuring items, be sure to restart the printer.

- NO
Does not reset the NV memory and returns to the menu.

5.3.6 USB

❖ *Adobe Protocol*

To set the Adobe Protocol choose one of the following:

- TBCP (default)
- RAW
- Standard
- BCP

Look

<For Mac OS 8.6 to 9.2 only>

If you use this printer with a USB interface cable, you will need to change the Adobe Protocol setting to RAW. For details about how to change the Adobe Protocol setting, see the Driver Installation Guide Macintosh for USB Users section.

CHAPTER 6

DEALING WITH PROBLEMS

6.1 Troubleshooting

Read this chapter to learn how to fix printer problems.

<If it looks like you are unable to fix the problem>

Turn off the printer, disconnect the power cord from the AC outlet, and contact your dealer or Brother authorized service representative for assistance.

⚠ WARNING

Do not make any changes or modifications to the equipment, as this may cause a fire or an electric shock.

⚠ CAUTION

Turn off the printer and disconnect the power cord from the AC outlet before performing maintenance on the printer. Failure to turn off the printer and disconnect the power cord may result in an electric shock.

6.2 Power Problems

Symptom	Possible Cause	Action
No power	Is the printer off?	Press the [I] on the power switch to turn on the printer. See 3.2.1 "Turn On the Printer"
	Is the power cord loose or disconnected?	Turn off the printer and connect the power cord properly. Turn on the printer again.
	Is the printer connected to a correctly rated outlet?	Connect the printer to a power outlet that you know works. Do not connect any other equipment to the outlet. Do not connect the printer to an auxiliary power outlet on the rear of a computer.
The printer frequently turns off	Is the power cord loose or disconnected?	Turn off the printer and connect the power cord correctly. Turn on the printer again.
	The printer is defective.	Turn off the printer immediately, disconnect the power cord from the outlet, and contact your dealer or Brother authorized service representative.

6.3 Printing Problems

6.3.1 Indicators are on, flashing, or off.

Symptom	Possible Cause	Action
The Alarm lamp is on	Is there an error message on the control panel display?	Check the message and rectify the error accordingly. See 6.7 "What to Do When an Error Message Appears"
The Alarm lamp is flashing	A problem that the user cannot rectify has occurred.	Note the error code on the display, turn off the printer immediately, disconnect the power cord from the outlet, and contact your dealer or Brother authorized service representative.
The Print Ready lamp is off	Is the control panel display on the menu screen?	Press the Menu button on the control panel to go back to the print screen. See 5.1.3 "Buttons"
The Print Ready lamp is not on or flashing after executing the print command	Is the parallel, USB, or Ethernet interface cable loose or disconnected?	Turn off the printer and check the interface cable. If necessary, reconnect.
	Is the network expansion card loose?	Turn off the printer and reinstall the network expansion card into the printer.
	Does the parallel, USB, or Ethernet interface cable meet the required printer specifications?	Use only the recommended parallel or USB interface cables for the printer. 10Base-T and 100Base-TX Ethernet interface cables are compatible with the printer. Use twisted pair cables suitable for network connections. A Category 5 100Base-TX is required.
	Is the computer configured correctly?	Check the following settings on your computer and reconfigure any that are not correct. <ul style="list-style-type: none"> • Make sure that the appropriate printer driver for your operating system is installed. • Make sure that the port is set correctly in the printer driver.
	Is the printer IP address correct? (When using TCP/IP.)	Consult your system administrator to obtain a valid IP address. Use the printer configuration list to confirm the IP address.

Symptom	Possible Cause	Action
(Continued from previous page) The Print Ready lamp is not on or flashing after executing the print command	Is the printer properly configured for use through a network? (When on a network.)	Print the printer configuration list to check the network settings. Correct any inappropriate settings. See "Network User's Guide"
	The network has a problem. (When on a network).	Check that the printer is on and execute the print command from the computer one more time. If the problem persists, consult your system administrator.
	Is the printer off?	Press the [I] on the power switch to turn on the printer. See 3.2.1 "Turn On the Printer"
Printouts are not output from the Printer even though the Print Ready lamp is on or flashing	There may be data remaining in the printer.	Cancel printing or force the remaining data to be printed out. See "Network User's Guide"

6.3.2 Cannot Print in Windows



Symptom	Possible Cause	Action
The printer does not print	Does "Pause Printing" appear in the printer window?	When printing stops because of an error, the printer sometimes switches to the "Pause Printing" state. Follow the procedure below to release the printer from the "Pause Printing" state. <ol style="list-style-type: none"> 1. On the Start menu, point to Settings and click Printers. 2. Double-click the appropriate printer. 3. In the printer window, click the Printer menu. 4. On the Printer menu, if "Pause Printing" is selected, click it to release.
	Is the printer off?	Press the [I] on the power switch to turn on the printer. See 3.2.1 "Turn On the Printer"
	Is the parallel, USB, or Ethernet interface cable loose or disconnected?	Turn off the printer and check the interface cable. If necessary, reconnect.
Cannot print with TCP/IP	Is the printer IP address set correctly? (When using TCP/IP.)	The IP address might be different. Consult your system administrator and set the correct IP address. Use the printer configuration list to confirm the current IP address.
	Is there a reception filter?	Consult your system administrator to find out if there is a reception filter set.
An error message appears on the computer screen	A printer error has occurred.	Check the message and rectify the error accordingly.

6.3.3 Cannot Print from a Macintosh Computer



Symptom	Possible Cause	Action
The printer does not appear in the Selector window	Is the printer off?	Press the [I] on the power switch to turn on the printer. See 3.2.1 "Turn On the Printer"
	Is the USB or Ethernet interface cable loose or disconnected?	Turn off the printer and check the interface cable. If necessary, reconnect.
	Is the network expansion card loose or disconnected?	Turn off the printer and reinstall the network expansion card into the printer.
	Are the zone and printer names correctly specified?	The zone or printer names might be incorrect. Ask your system administrator for the correct settings. Use the printer configuration list to confirm the current printer settings. See 8.4.1 "Confirming Printer Configuration and Network Settings"
An error message appears on the computer screen	Are you using the appropriate Mac OS?	Print from a computer with an operating system compatible with the printer. This printer supports Mac OS 8.1 to Mac OS X.
	The printer is defective.	Check the message and rectify the error accordingly.

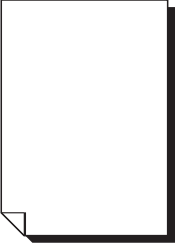

6.4 *Print Quality Problems*

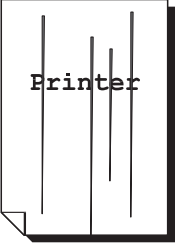

6.4.1 *Blank or Completely Black Pages are Output*

Symptom	Possible Cause	Action
Nothing is printed 	Two or more sheets may be feeding at once.	Remove the paper stack from the tray, fan it, and reinsert it.
	The print head cartridge is old or damaged.	Replace the print head cartridge. See 8.2.2 "Replacing the Print Head Cartridge"
	The power supply is defective.	Contact your dealer or Brother authorized service representative.
Output sheets are completely black 	The print head cartridge is old or damaged.	Replace the print head cartridge. See 8.2.2 "Replacing the Print Head Cartridge"
	The power supply is defective.	Contact your dealer or Brother authorized service representative.

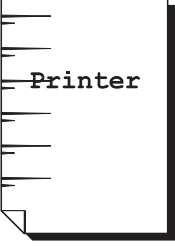
6.4.2 Faded or Dirty Printouts, White Areas (drop-outs), Creases, Blurs

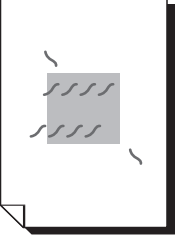
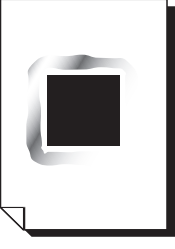
Symptom	Possible Cause	Action
Faded printouts 	Is the media suitable?	Replace the media with a recommend size and type, and confirm that your printer driver settings are correct. See 4.1 "Suitable and Unsuitable Paper Types"
	Is the paper damp?	Replace the paper. See 4.2 "Loading Paper"
	The print head cartridge is old or damaged.	Replace the print head cartridge. Reference 8.2.2 "Replacing the Print Head Cartridge"
	Is the printer driver toner save function active?	In the printer driver, deactivate the toner save function on the "Graphics" tab (Windows), or the "General" dialog box (Macintosh). See "Help"
	The power supply is defective.	Contact your dealer or Brother authorized service representative.
Dirty spots are printed 	Is the media suitable? Are you using preprinted or inkjet paper?	Replace the media with a recommend size and type, and confirm that your printer driver settings are correct. See 4.1 "Suitable and Unsuitable Paper Types"
	The print head cartridge is old or damaged.	Replace the print head cartridge. See 8.2.2 "Replacing the Print Head Cartridge"
Vertical black lines 	The print head cartridge or transfer roll cartridge is old or damaged.	Check the print head cartridge and transfer roll cartridge and replace them as necessary. See 8.2.2 "Replacing the Print Head Cartridge" See 8.3.2 "Replacing the Transfer Roll Cartridge"

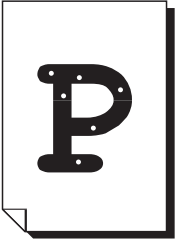
Symptom	Possible Cause	Action
Recurring smudges 	Dirt in the paper path. The print head cartridge or transfer roll cartridge is old or damaged.	Print several blank sheets. Check the print head cartridge and transfer roll cartridge and replace them as necessary. See 8.2.2 “Replacing the Print Head Cartridge” See 8.3.2 “Replacing the Transfer Roll Cartridge”
Ink smears when rubbed. 	Is the paper damp?	Replace the paper. Reference 4.2 “Loading Paper”
Hair-like marks appear around black halftone printing 	The paper was left unwrapped for a long time (especially in a dry environment).	Replace the paper. See 4.2 “Loading Paper”
Shadows appear around areas of dense black printing. 	Is the media suitable?	Replace the media with a recommend size and type, and confirm that your printer driver settings are correct. See 4.1 “Suitable and Unsuitable Paper Types”
	The transfer roll cartridge is old or damaged.	Replace the transfer roll cartridge. See 8.3.2 “Replacing the Transfer Roll Cartridge”

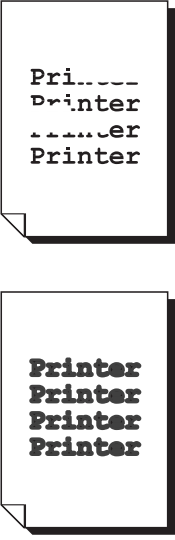
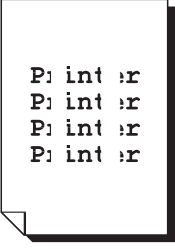
Symptom	Possible Cause	Action
<p>White spots appear in areas of dense black printing.</p> 	<p>Is the media suitable? Is the media folded or creased?</p>	<p>Replace the media with a recommend size and type, and confirm that your printer driver settings are correct. See 4.1 “Suitable and Unsuitable Paper Types”</p>
	<p>The print head cartridge is old or damaged.</p>	<p>Replace the print head cartridge. See 8.2.2 “Replacing the Print Head Cartridge”</p>
<p>Color around the edge of printing is incorrect.</p> 	<p>Is the color registration correctly adjusted?</p>	<p>Adjust the color registration. See 1.1 “Adjusting Color Registration”</p>
<p>Partial blanks</p> 	<p>Is the paper damp?</p>	<p>Replace the paper. See 4.2 “Loading Paper”</p>
	<p>Is the media suitable?</p>	<p>Replace the media with a recommend size and type, and confirm that your printer driver settings are correct. See 4.1 “Suitable and Unsuitable Paper Types”</p>
	<p>Is the transfer roll cartridge properly installed in the printer?</p>	<p>Make sure that the transfer roll cartridge is properly installed. See 8.3.2 “Replacing the Transfer Roll Cartridge”</p>
<p>Vertical blanks</p> 	<p>Is the print head cartridge properly installed in the printer?</p>	<p>Make sure that the print head cartridge is properly installed. See 8.2.2 “Replacing the Print Head Cartridge”</p>
	<p>The print head cartridge or transfer roll cartridge is old or damaged.</p>	<p>Check the print head cartridge and transfer roll cartridge and replace them as necessary. See 8.2.2 “Replacing the Print Head Cartridge” See 8.3.2 “Replacing the Transfer Roll Cartridge”</p>

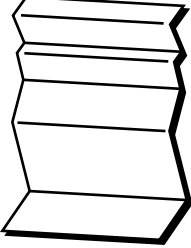
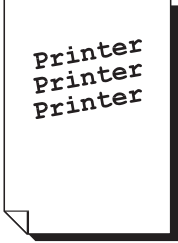
Symptom	Possible Cause	Action
<p data-bbox="164 286 347 315">Creased paper</p> 	Is the paper damp?	Replace the paper. See 4.2 "Loading Paper"
	Is the media suitable? Are you using warped paper?	Replace the media with a recommend size and type, and confirm that your printer driver settings are correct. See 4.1 "Suitable and Unsuitable Paper Types"
	Is the paper tray properly inserted into the printer?	Push the paper tray completely back into the printer.
	Is there paper or a foreign object jammed in the printer?	Turn the power off and remove the jammed paper or foreign object. If you cannot remove the obstruction, turn off the printer and contact your dealer or Brother authorized service representative. Do not attempt to disassemble the printer.
	Is the transfer roll cartridge properly installed in the printer?	Make sure that the transfer roll cartridge is properly installed. See 8.3.2 "Replacing the Transfer Roll Cartridge"
<p data-bbox="164 992 424 1081">Slanted printing, Incorrectly positioned printing</p> 	Are the paper guides in the paper tray set correctly?	In the paper tray, set the side and end guides to their correct positions. See 4.2.1 "Load Paper in the Paper Tray" See 4.2.2 "Load A5 Paper in the Paper Tray/Changing the Paper Size from A5"
	Is the paper guide in the multi-purpose tray set at the correct mark?	Set the paper guide in the multi-purpose tray at the correct mark. See 4.2.3 "Load Paper into the Multi-purpose Tray"
	Did you install the A5 spacer when loading A5 paper into the paper tray?	Make sure that the A5 spacer is properly installed next to the end guide in the paper tray. See 4.2.2 "Load A5 Paper in the Paper Tray/Changing the Paper Size from A5"

6.4.3 Unsatisfactory Printing

Symptom	Possible Cause	Action
Unsatisfactory transparency sheets	Is the transparency sheet suitable?	Use transparency sheets suitable for use with this printer.
	Is the media properly loaded into the multi-purpose tray?	Make sure that the transparency sheets are properly loaded into the multi-purpose tray. See 3.7.3 "Printing on Transparency Sheets"
	Is the printer driver configured to print transparency sheets?	Set the printer driver for transparency sheets on the "Paper/Output" tab (in Windows) or the "page Setup" dialog box (with Macintosh). See 3.7.3 "3 "Printing on Transparency Sheets"
Unsatisfactory envelopes	Are the envelopes of a suitable type?	Use envelopes suitable for use with this printer. See 4.1 "Suitable and Unsuitable Paper Types"
	Is the media properly loaded into the multi-purpose tray?	Make sure the envelopes are properly loaded into the multi purpose tray. See 3.7.1 "Printing on Envelopes"
	Is the printer driver configured to print envelopes?	Set the printer driver for envelopes in the "Paper/Output" tab (in Windows) or the "Page Setup" dialog box (with Macintosh). See 3.7.1 "Printing on Envelopes"
Unsatisfactory printing	Is the printer driver toner save or low-resolution functions active?	Change the printer driver settings on the "Graphics" tab (in Windows) or the "General" dialog box (with Macintosh). See "Help"

6.5 Paper Feed Problems

Symptom	Possible Cause	Action
Paper does not feed, Paper jams, Several sheets feed at once, Paper does not feed straight	Is the media properly loaded? If using special paper, is the media properly loaded into the multi-purpose tray?	Make sure that the media is properly loaded. When using media such as transparency sheets, label sheets, or envelopes, fan the stack before loading so that there is air between the sheets. See 4.2 "Loading Paper"
	Is the paper damp?	Replace the paper. See 4.2 "Loading Paper"
	Is the media suitable?	Replace the media with a size and type of media suitable for use with this printer. See 4.1 "Suitable and Unsuitable Paper Types"
	Is the paper tray properly inserted into the printer?	Push the paper tray completely back into the printer.
	Is there paper jammed in the printer?	Remove the jammed paper. Also, thoroughly inspect the inside of the printer and remove any tape or adhesive found along the paper path. See Chapter 7 "Paper Jams"
	Is the printer level?	Reposition the printer on a flat, stable surface. See "Safety Precautions"
	Is the printer driver paper feed method correctly set?	Make sure that the printer driver paper feed method is correctly set. Also, when an optional tray module is present, you must reconfigure the printer to use the module as tray 2 or 3. See "Help"
	Are the paper guides of the paper tray set correctly?	In the paper tray, set the side and end guides in the correct positions. See 4.2.1 "Load Paper in the Paper Tray" See 4.2.2 "Load A5 Paper in the Paper Tray/Changing the Paper Size from A5"
	Is the paper guide in the multi-purpose tray set at the correct mark?	Set the paper guide in the multi-purpose tray at the correct mark. See 4.2.3 "Load Paper into the Multi-purpose Tray"

Symptom	Possible Cause	Action
(Continued from previous page) Paper does not feed, Paper jams, Several sheets feed at once, Paper does not feed straight	Did you install the A5 spacer when loading A5 paper into the paper tray?	Make sure that the A5 spacer is properly installed next to the end guide in the paper tray. See 4.2.2 "Load A5 Paper in the Paper Tray/Changing the Paper Size from A5"

6.6 Others Problems

6.6.1 Network Problems

Symptom	Possible Cause	Action
The IP address changes when turning on the printer	Is the printer set to acquire an IP address through a DHCP server?	Set the IP address acquisition method to "Panel". See 1.2.1 "Setting an IP Address".
Cannot use a web browser to manage the printer.	Is the printer off?	Press the [I] on the power switch to turn on the printer. See 3.2.1 "Turn On the Printer"
	Is the Ethernet cable loose or disconnected?	Turn off the printer and check the Ethernet cable. If necessary, reconnect.
	Is the printer's Internet address correct?	Confirm that the printer Internet address is correct. If the problem persists, use an IP address to connect to the printer instead.
	Is the printer's IP address correct?	The IP address might be set incorrectly. Ask your system administrator for the correct settings. Use the printer configuration list to confirm the current IP address.
	Are you using a proxy server?	Certain proxy servers block access to the printer. Configure your Web browser so that it does not use the proxy server or set the address you want to access so that it does not go through the proxy server.
	Is the port number correct?	The default port number is "80". Specify the correct port number.

6.6.2 Other Problems

Symptom	Possible Cause	Action
Cannot print in color	Is the printer driver set to Black/White printing?	Change the printer driver settings in the "Paper/Output" or "Graphics" tab (Windows), or the "General" dialog box (Macintosh). See "Help"
Paper does not feed from the specified tray	Are the application settings overriding the printer driver settings?	Set the paper tray in the application to the same paper tray set in the printer driver.
Printing is slow	Is the printer driver color mode set to color printing even when you are printing in monochrome?	Change the printer driver settings in the "Paper/Output" or "Graphics" tab (Windows), or the "General" dialog box (Macintosh). See "Help"
	Is the energy save mode timeout too short?	When the printer is in energy save mode, it takes longer than normal to begin printing if it receives a print request. On the control panel, set a longer energy save mode timeout. See 5.3 "List of Menu Items"
Unusual noises are coming from the printer	Is the printer level?	Reposition the printer on a flat, stable surface. See "Safety Precautions"
	Is the paper tray properly inserted into the printer?	Push the paper tray completely back into the printer.
	Is there paper or a foreign object jammed in the printer?	Turn off the printer and remove the jammed paper or foreign object. When you cannot remove the obstruction, turn off the printer and contact your dealer or Brother authorized service representative. Do not attempt to disassemble the printer.
There is condensation in the printer	-	On the control panel, set the energy save mode timeout to one hour or more and leave the printer on. After leaving the printer for an hour to allow condensation to dissipate, you can use the printer normally. See 5.3 "List of Menu Items"

6.7 What to Do When an Error Message Appears

This section describes error messages and their meanings, as well as what to do when they appear.

When an error message is displayed, find the corresponding message in the table below and follow the procedure herein.

⇒ **Note**

When the message is too long to fit on the display, the screen changes every 3 seconds, displaying the message in segments.

Message	Meaning and Action
xxx-xxx Turn OFF the Power	The printer is not functioning correctly. Action: Turn off the printer and turn it on again. When the same message reappears after taking this action, write the error code displayed, turn off the printer, and contact your dealer or Brother authorized service representative.

“xxx-xxx” indicates numeric characters.

Message	Meaning and Action
Replace Yellow Toner (Y)	The yellow toner cartridge is empty. Action: Replace the yellow toner cartridge. See 8.1.2 "Replacing the Toner Cartridges"
Reinsert Yellow Toner (Y)	There is no yellow toner cartridge inserted in the printer or the cartridge is improperly set. Action: Grip the levers at each end of the yellow toner cartridge with your fingers, then push down firmly to rotate the levers forward to install the cartridge. See 8.1.2 "Replacing the Toner Cartridges"
CTD Sensor Need Maintenance	It is time to check the density sensor. Action: Remove the transfer roll cartridge and check the cleanliness of the density sensor. See 6.10 "Cleaning the Density Sensor"
Clean Up CTD Sensor	The density sensor is dirty. Action: Remove the transfer roll cartridge and clean the density sensor. See 6.10 "Cleaning the Density Sensor"
Regi Jam Open A-Cover	There is paper jammed in the printer. Action: Press button A, open the front cover and remove the jammed media. Make sure that there is no paper jammed in the paper trays. See Chapter 7 "Paper Jams"
Fuser Jam Open A/B-Cover	There is paper jammed in the printer. Action: Press button A or B, open the front cover and remove the jammed media. Make sure there is no paper jammed in the paper trays. See 7.4 "Paper Jams Between the Print Head Cartridge and Fuser Cartridge"
Duplex Jam Open B-Cover	There is paper jammed in the paper rotator used for duplex printing. Action: Press button B, open the front cover and remove the jammed media. See 7.5 "Paper Jams in the Paper Rotator"
Feed Jam Check Tray	There is paper jammed in the multi-purpose tray, the paper tray, or the optional tray module (2 shelves) if installed. Action: Pull out the tray and remove the jammed media. See 7.2 "Paper Jams in Multi-purpose Tray" See 7.3 "Paper Jams in the Paper Tray" See 7.6 "Paper Jams in the Tray Module (2 Shelves)"
Print Head Cart ID Error	The print head cartridge is defective. Action: Replace the print head cartridge. See 8.2.2 "Replacing the Print Head Cartridge"

Message	Meaning and Action
Replace Cyan Toner (C)	The cyan toner cartridge is empty. Action: Replace the cyan toner cartridge. See 8.1.2 "Replacing the Toner Cartridges"
Reinsert Cyan Toner (C)	There is no cyan toner cartridge inserted in the printer or the cartridge is improperly set. Action: Grip the levers at each end of the cyan toner cartridge with your fingers, then push down firmly to rotate the levers forward to install the cartridge. See 8.1.2 "Replacing the Toner Cartridges"
Sys data cleared Press Set	All system settings stored in the NV memory were deleted. Action: Follow the procedure below to reset the NV memory. 1 Press the <Form Feed/Set> button. The printer settings may be deleted when you reset the NV memory. Print the printer configuration list and the panel settings list to confirm settings. See 8.4.1 "Confirming Printer Configuration and Network Settings" See 5.3 "List of Menu Items"
No Paper in All Tray	There is no paper in any of the paper trays. Action: Load paper into the trays. See 4.2.1 "Load Paper in the Paper Tray"
Push in All Tray	One of the trays is not properly inserted. Action: Push the all paper trays completely back into the printer.
Disk Full Please Press Set	The hard disk became full during electronic sorting and data writing was halted. Action: Press the <Form Feed/Set> button. It deletes print jobs from the printer. Print with one of the following methods: <ul style="list-style-type: none"> • Print fewer pages at a time. • Deactivate the printer driver hard disk setting. See 3.6 "Changing the Configuration for Options"
Check Paper in MP Tray	Paper is not properly loaded in the multi-purpose tray or is different from that specified on the computer. Action: Make sure the paper is properly loaded into the multi-purpose tray. If the computer settings are incorrect, cancel printing. Check the following settings on your computer, reconfigure any that are incorrect, and reprint. <ul style="list-style-type: none"> • Is the correct paper tray specified? • Is the correct paper size specified? See 4.2.3 "Load Paper into the Multi-purpose Tray" See 3.5.2 "Cancel Printing at the Control Panel"
Replace Transfer Roll	The transfer roll cartridge needs to be replaced. Action: Replace the transfer roll cartridge. See 8.3.2 "Replacing the Transfer Roll Cartridge"

Message	Meaning and Action
Reinsert Transfer Roll	The transfer roll cartridge is not inserted in the printer or the cartridge is set improperly. Action: Push the transfer roll cartridge all the way into the printer. See 8.3.2 “Replacing the Transfer Roll Cartridge”
Replace Print Head Cartridge	The print head cartridge needs to be replaced. Action: Replace the print head cartridge. See 8.2.2 “Replacing the Print Head Cartridge”
Set Print Head Cartridge	The print head cartridge is not inserted in the printer or the cartridge is set improperly. Action: Push the print head cartridge all the way into the printer. See 8.2.2 “Replacing the Print Head Cartridge”
No Paper in Tray1	There is no paper in tray 1. Action: Load paper into paper tray 1. See 4.2.1 “Load Paper in the Paper Tray”
Load xxxx in N	Paper size xxxx is not loaded in tray N or is different from that specified on the computer. Action: Load paper xxxx into tray N. If the computer settings are incorrect, cancel printing. Check the following settings on your computer, reconfigure any that are incorrect, and reprint. <ul style="list-style-type: none"> • Is the correct paper tray specified? • Is the correct paper size specified? See 4.2.1 “Load Paper in the Paper Tray” See 3.5.2 “Cancel Printing at the Control Panel”
Check Paper in N	Paper is not properly loaded in tray N or is different from that specified on the computer. Action: Pull out tray N and check the paper. If the computer settings are incorrect, cancel printing. Check the following settings on your computer, reconfigure any that are incorrect, and reprint. See 4.2.1 “Load Paper in the Paper Tray” See 3.5.2 “Cancel Printing at the Control Panel”

“N” is a paper tray.

“xxxx” represents the paper size and orientation.

Message	Meaning and Action
Push in the Tray	None of the trays are properly inserted. Action: Push the all paper trays completely back into the printer.
Empty Exit Tray	The face down tray is full. Action: Remove the paper from the face down tray.
Replace Black Toner (K)	The black toner cartridge is empty. Action: Replace the black toner cartridge. See 8.1.2 "Replacing the Toner Cartridges"
Reinsert Black Toner (K)	There is no black toner cartridge inserted in the printer or the cartridge is improperly set. Action: Grip the levers at each end of the black toner cartridge with your fingers, then push down firmly to rotate the levers forward to install the cartridge. See 8.1.2 "Replacing the Toner Cartridges"
Operation Error Please Press Set	The request from the computer could not be printed. Action: Press the <Form Feed/Set> button and cancel printing. Check the printer driver settings and reprint.
Operation Denied While Printing	An illegal operation was performed on the control panel during printing. Wait until printing finishes.
ServCallJ1	This is a warning message. Contact your dealer or Brother authorized service representative.
Close Front Cover	The front cover is open. Action: Make sure that the front cover is properly closed.
Replace Magenta Toner (M)	The magenta toner cartridge is empty. Action: Replace the magenta toner cartridge. See 8.1.2 "Replacing the Toner Cartridges"
Reinsert Magenta Toner (M)	There is no magenta toner cartridge inserted in the printer or the cartridge is improperly set. See 8.1.2 "Replacing the Toner Cartridges"
Out of Memory Please Press Set	There is not enough memory available for the printer to function normally. Action: Press the <Form Feed/Set> button and cancel printing. Install a memory expansion card and reprint. See Appendix A.5 "Adding the Expansion Memory". If you are unable to install a memory expansion card, print after configuring the printer driver as follows: <ul style="list-style-type: none"> • Turn off the Duplex Printing and Multiple Page setting. • Change the setting in 'Document Types' to 'Normal' in the "Graphics" tab (Windows), or the "General" dialog box (Macintosh). Note that this lowers image quality. See "Help"

6.8 *The Alarm Indicator is On or Flashing*

The red alarm indicator on the control panel indicates that there is a problem with the printer. Refer to the sections below.

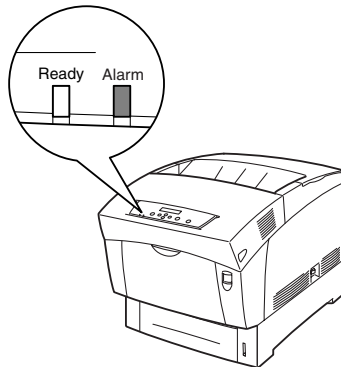

6.8.1 *The Alarm Lamp is On*

When the alarm lamp is on, it indicates a paper jam or other problem that you can rectify yourself. Rectify the problem according to the message displayed on the control panel.

 **See**

For detailed information about the meaning of error messages, refer to 6.7 “What to Do When an Error Message Appears”, and correct the error as instructed.

6.8.2 *The Alarm Lamp is Flashing*

When the alarm lamp is flashing, it indicates a problem that you cannot rectify yourself. Write down the message and error code displayed, turn off the printer and contact your dealer or Brother authorized service representative.

6.9 Forcing the Printer to Print Remaining Data (When Printing is Halted)

If the printer stops receiving data half way through print job, the printer will wait for a pre-determined time, during this wait, the control panel will display “Data Wait”. If you wish to, you can force the printer to print the data that it has already received. Refer to the following steps for more information.

See

The default job timeout is 30 seconds. You can set the job timeout between 5 and 300 seconds on the control panel. For details about the job timeout function, refer to 5.3 “List of Menu Items”.

Follow the procedure below. Use the following control panel buttons.

See

For details about control panel operations, refer to 5.2 “Basic Menu Operation”.

(The printer is processing)

- 1.** Press the <Form Feed/Set> button once. The remaining data in the printer is printed out.
- 2.** When processing is finished, the print screen reappears.
(The print screen. The printer is ready to print.)

6.10 *Cleaning the Density Sensor*

When the printer's density sensor is dirty, follow the procedure below to clean it.

1. On the printer's right side, press the side of the power switch marked [O] to turn off the printer.

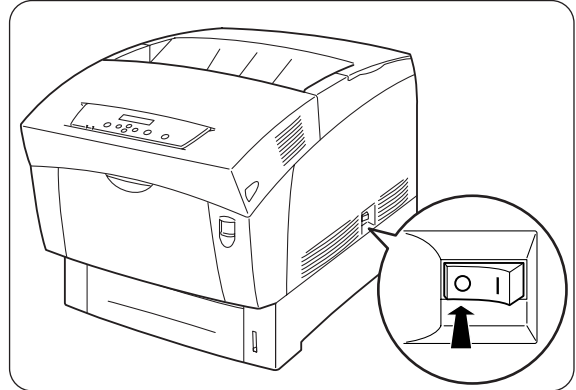

2. Push up button "A" (1) and fully open the front cover (2).

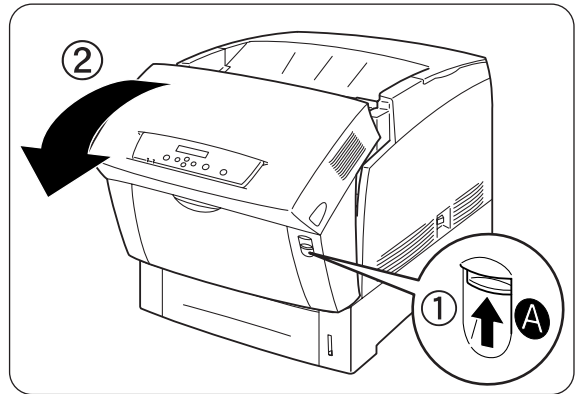

3. Grip the orange tabs at both ends of the transfer roll and gently lift it out of the printer.

 **Look**

Lift the roll carefully to prevent waste toner from spilling out.

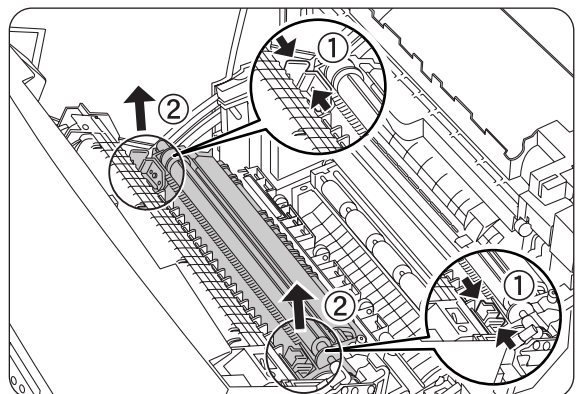

4. Gently wipe the density sensor window with a clean dry cloth or cotton swab.

Look

Do not allow anything hard to come in contact with the density sensor window. Do not use excessive force to clean the window.

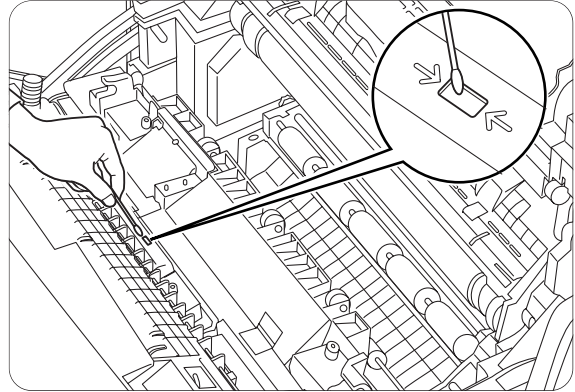

5. Replace the transfer roll cartridge. Grip the orange U-shaped tabs as shown.

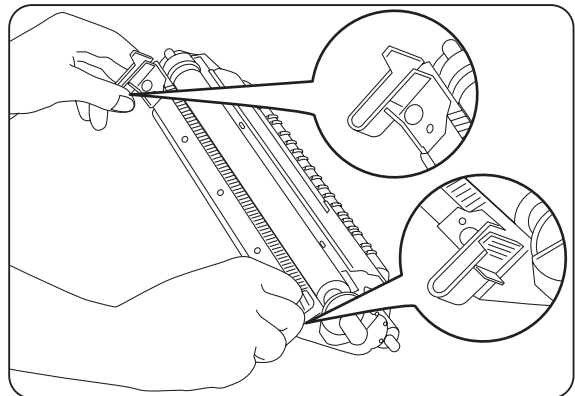

6. Insert the pins at both ends of the transfer roll cartridge into the bearings inside the printer.

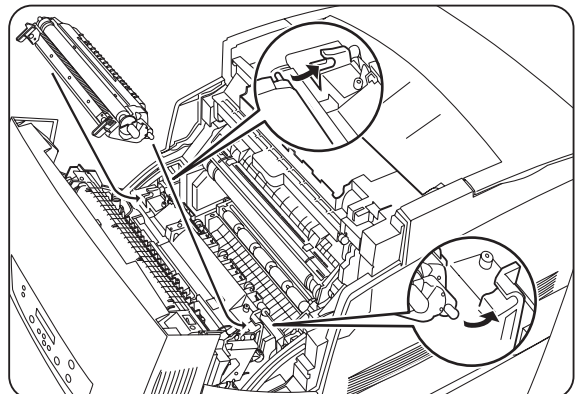

7. To lock the transfer roll cartridge into the printer, push down on the tabs until you hear a click.

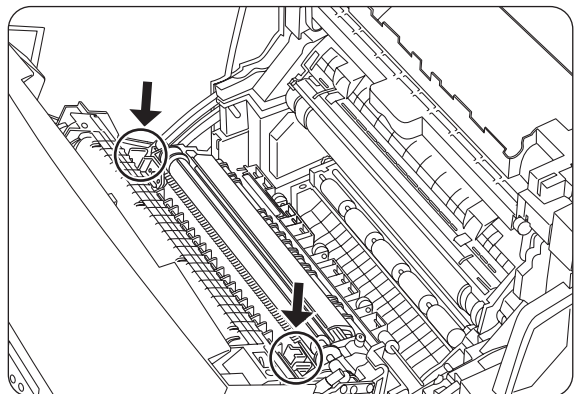

8. Close the front cover.

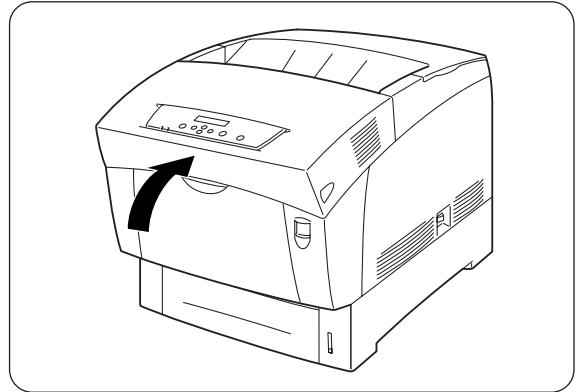

9. On the printer's right side, press the side of the power switch marked [I] to turn on the printer.

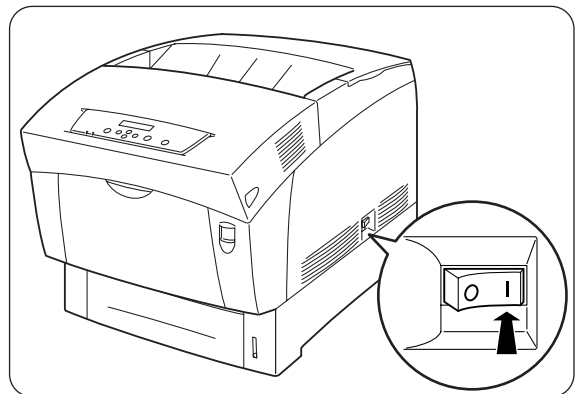

CHAPTER 7

PAPER JAMS

7.1 Clearing Paper Jams

If a paper jam occurs, printing stops and an error message appears on the control panel informing you of the location of the paper jam. To clear the paper jam, read the error message, refer to the appropriate section below, and follow the procedure.

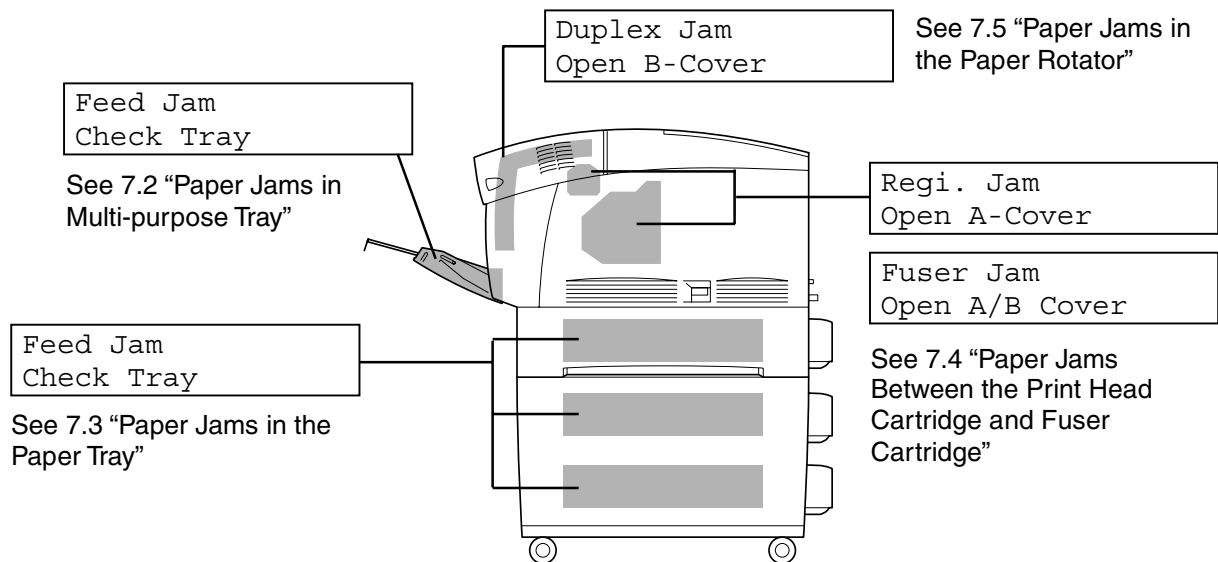

Look

Attempting to print while there is paper jammed in the printer may damage the printer. Remove jammed paper immediately.

Note

- If a paper jam occurs, the open cover lamps on the printer light according to the location of the jam. Press button A or B, open the front cover, and remove the jammed paper.
 - The illustration above shows the printer with the optional 2 Tray Module installed.
-

CAUTION

- When removing paper jams, make sure that no pieces of paper are left inside the printer, as this can cause a fire. If the paper is wrapped around the fuser or roller, or you cannot see the jam you are trying to clear, do not attempt to remove the paper by yourself, as this may cause injuries or burns. Turn off the printer immediately and contact your dealer or Brother authorized service representative.
- Never touch an area indicated by a high-temperature warning label (on or near the fuser unit). Touching these areas may result in burns.

Look

- If smoke comes out of the printer when a paper jam occurs, do not open the printer covers. Turn off the printer, remove the power cord from the AC outlet, and contact your dealer or Brother authorized service representative for assistance.
 - Remove jammed paper slowly and carefully to avoid tearing it.
-

Note

Paper jams can be caused by incorrect printer installation, or using unsuitable or low-quality paper. For details about the types of paper suitable for printing, refer to 4.1 “Suitable and Unsuitable Paper Types”.

7.2 Paper Jams in the Multi-purpose Tray

Follow the procedure below to remove the jammed paper.

1. Pull the jammed paper out of the multi-purpose tray.

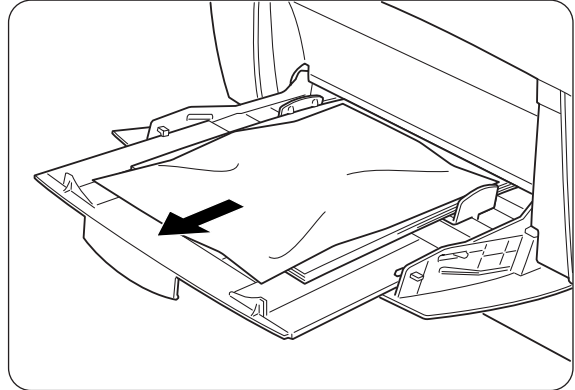

2. Push up button 'A' (1) and fully open the front cover (2). Confirm that there are no scraps of paper remaining inside the printer.

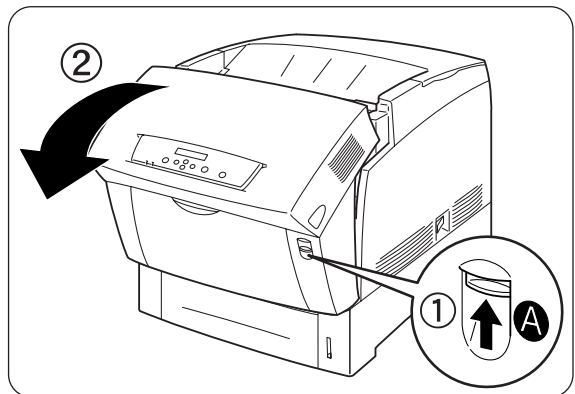

3. Close the front cover.

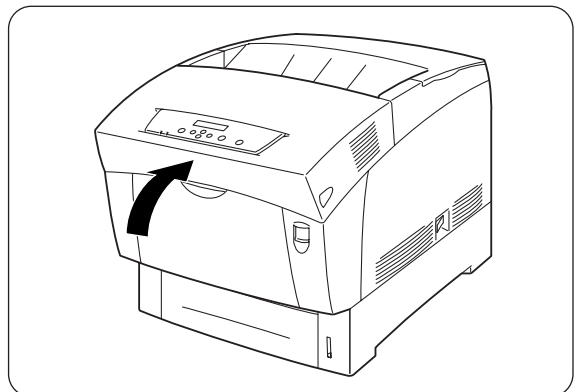

7.3 Paper Jams in the Paper Tray

If the Optional 2 Tray Module is not installed, follow the procedure below to remove paper jammed in the paper tray.

If the Optional 2 Tray Module is installed, look for the jammed paper sequentially, starting with the lowest tray. Follow the procedure described in 7.6 “Paper Jams in the 2 Tray Module”.

1. Slowly, completely remove the paper tray from the printer.

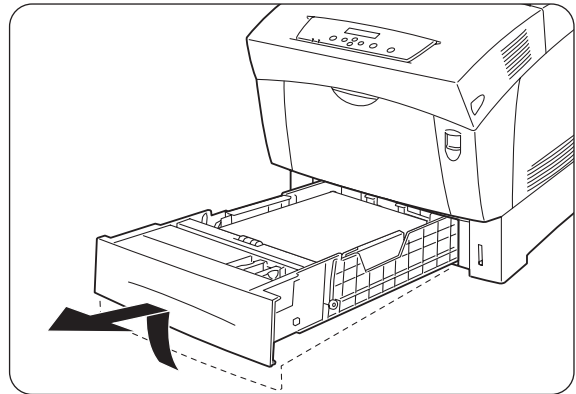

2. Remove all the jammed and/or creased paper from the tray.

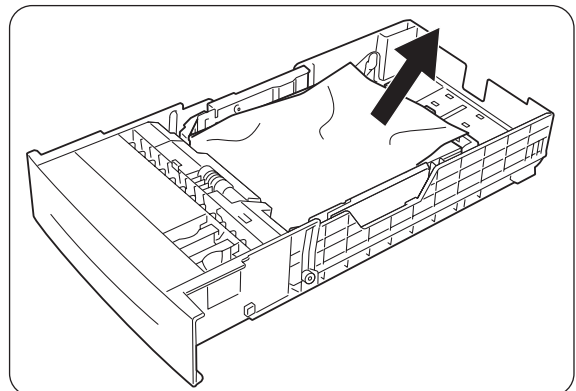

3. If there is jammed paper remaining inside the printer, pull it out carefully to avoid tearing it.

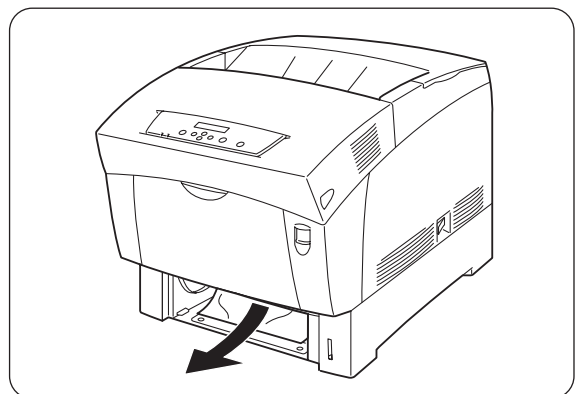

4. Push up button 'A' (1) and fully open the front cover (2). Confirm that there are no scraps of paper remaining inside the printer.

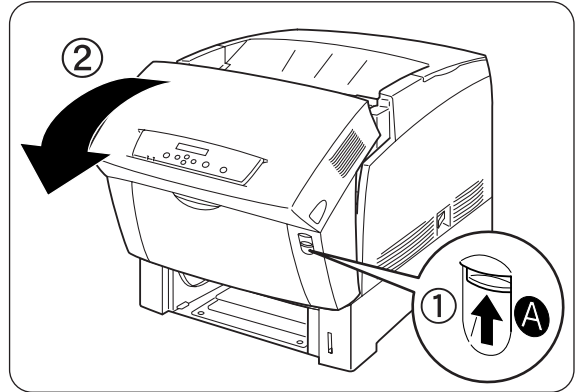

5. Close the front cover.

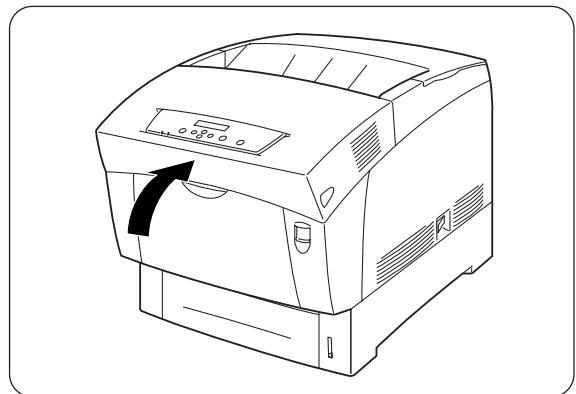

6. Hold the paper tray with both hands, align it with the opening in the printer and gently insert it.

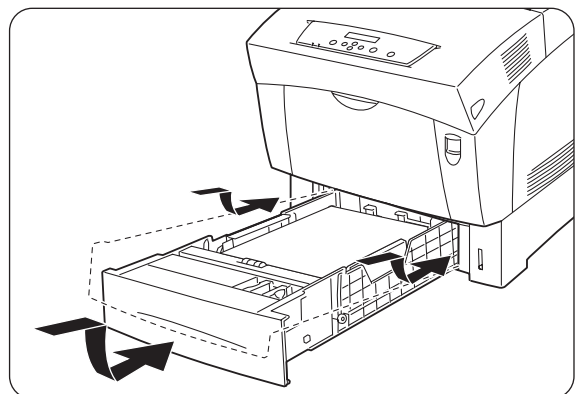

7. Push the paper tray completely back into the printer.

Look

Do use excessive force on the paper tray. Doing so could damage the paper tray or the inside of the printer.

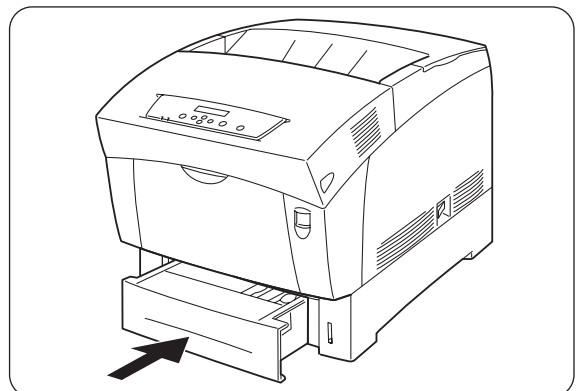

7.4 Paper Jams Between the Print Head Cartridge and the Fuser Cartridge

This section describes the procedures to remove paper jammed around the print head cartridge and in the fuser. Select the appropriate procedure according to the location of the jammed paper.

❖ Paper jams around the print head cartridge:

Follow the procedure below to remove the jammed paper.

1. Push up button 'A' (1) and fully open the front cover (2).

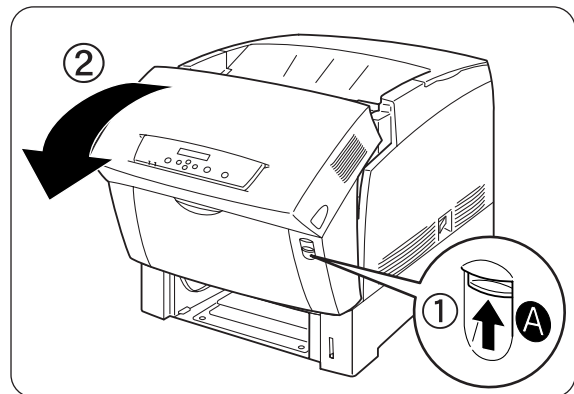

2. If there is paper jammed around the print head cartridge (Illustration A), continue following this procedure. If there is paper jammed around the fuser cartridge (Illustration B), follow the procedure for “Paper jams around the fuser cartridge” on the next page.

<Illustration A>

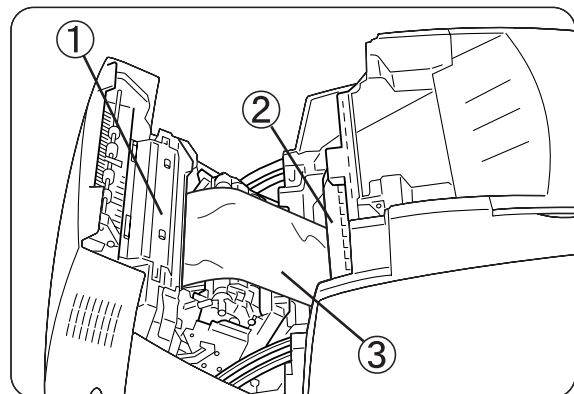

1. Fuser Cartridge
2. Print Head Cartridge
3. Paper

1. Fuser Cartridge
2. Paper
3. Print Head Cartridge

<Illustration B>

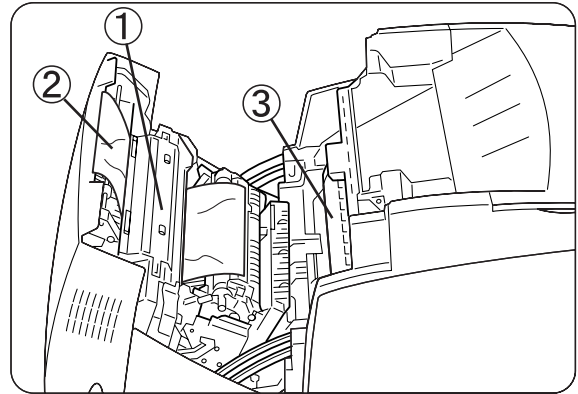

3. Open the fuser cartridge levers and remove the jammed paper. If the paper is torn, remove any scraps of paper remaining inside the printer.
4. Be sure to close the fuser cartridge levers after removing the jammed paper.

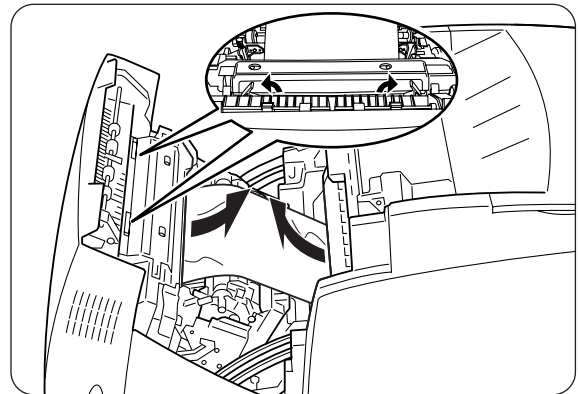

5. Close the front cover.

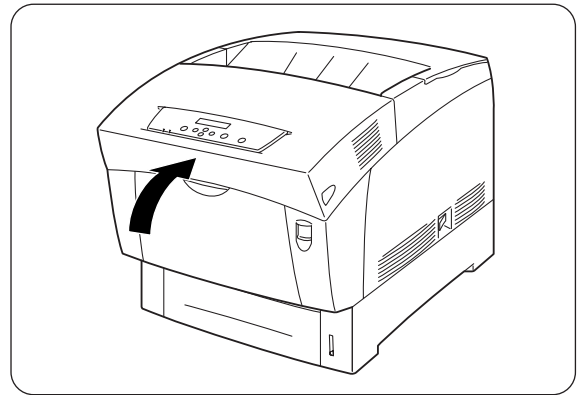

❖ Paper jams around the fuser cartridge:

Follow the procedure below to remove the jammed paper.

1. Push up button 'B' (1) and fully open the front cover (2).

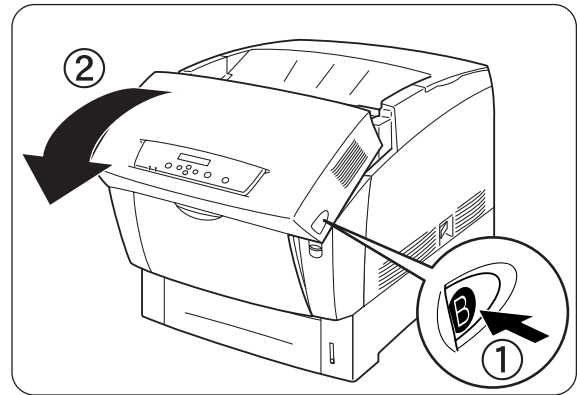

2. Open the levers at the ends of the fuser cartridge and remove the jammed paper. If the paper is torn, remove any scraps of paper remaining inside the printer.

Look

During operation, the fuser unit (heater) becomes very hot. To prevent burns, do not touch it with your bare hands.

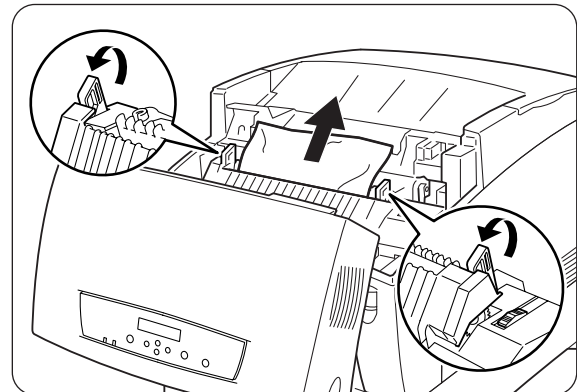

3. Be sure to close the levers at the ends of the fuser cartridge after removing the jammed paper.
4. Close the front cover.

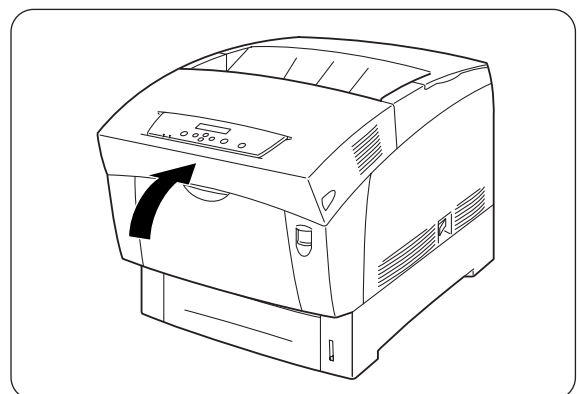

❖ ***Paper longer than 355.6 mm (14 in.) jams***

If paper longer than 355.6 mm (14 in.) jams in the printer, cut the paper as necessary and remove the paper from the location where it is jammed using the appropriate procedure. If the front cover is difficult to open, do not force it. Turn off the printer immediately and contact your dealer or Brother authorized service representative.

7.5 Paper Jams in the Paper Rotator

Follow the procedure below to remove the jammed paper.

- 1.** Push up button 'B' (1) and fully open the front cover (2).

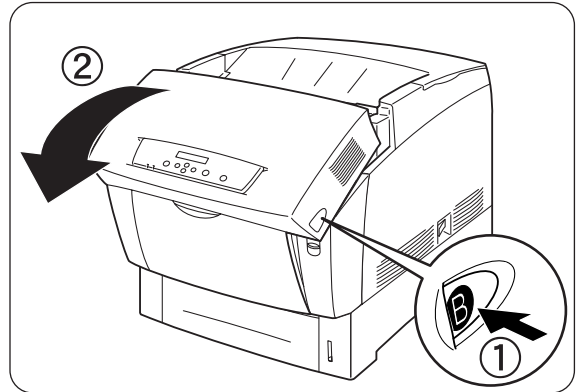

- 2.** Remove the jammed paper. If the paper is torn, remove any scraps of paper remaining inside the printer.

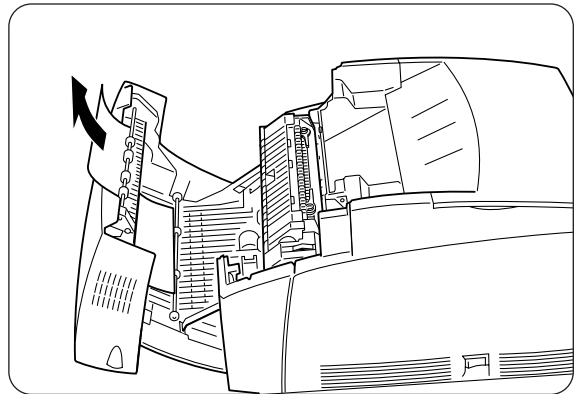

- 3.** Close the front cover.

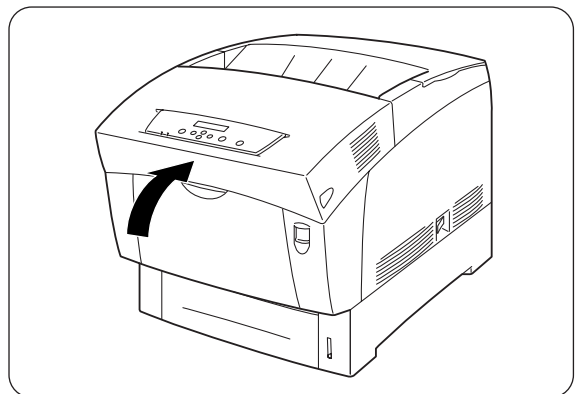

7.6 Paper Jams in the 2 Tray Module

Follow the procedure below to remove the jammed paper.

1. Starting with the bottom tray, pull out each tray until you find the jammed paper.

Look

Paper in the tray module feeds to the printer from the front of the trays, therefore paper jammed in the lower tray can block the upper tray of the module or the paper tray in the printer, preventing you from opening them. Look for the jammed paper sequentially, starting with the lowest tray.

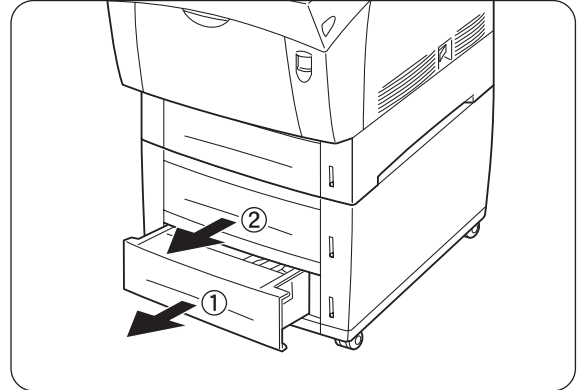

2. Remove all the jammed and/or creased paper from the tray.

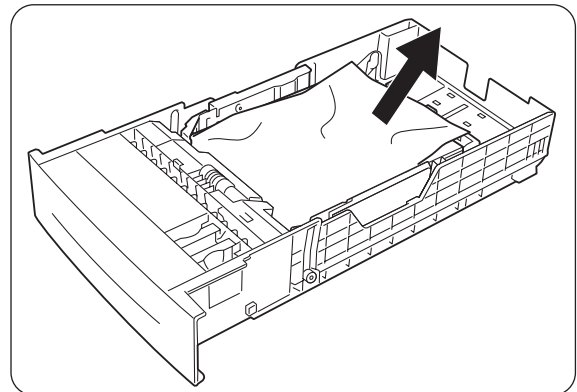

3. If there is jammed paper inside the printer, pull it out carefully to avoid tearing it.

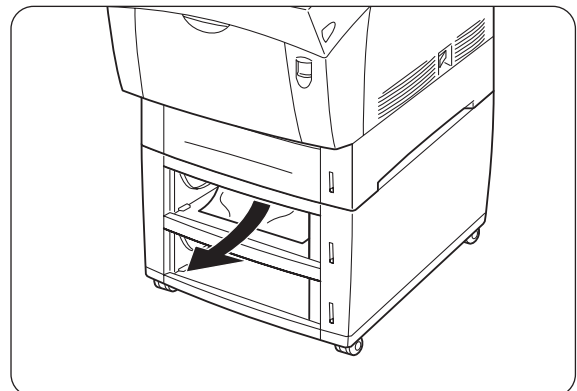

- 4.** Push up button 'A' (1) and fully open the front cover (2). Confirm that there are no scraps of paper remaining inside the printer.

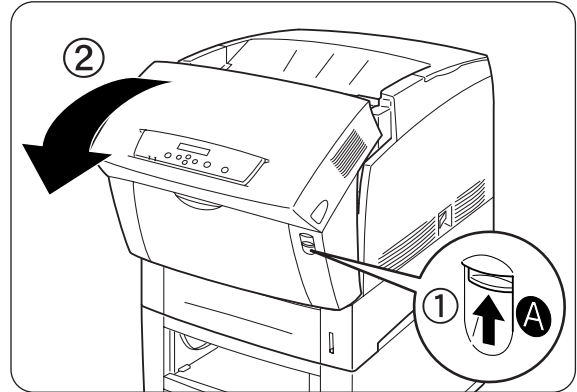

- 5.** Close the front cover.

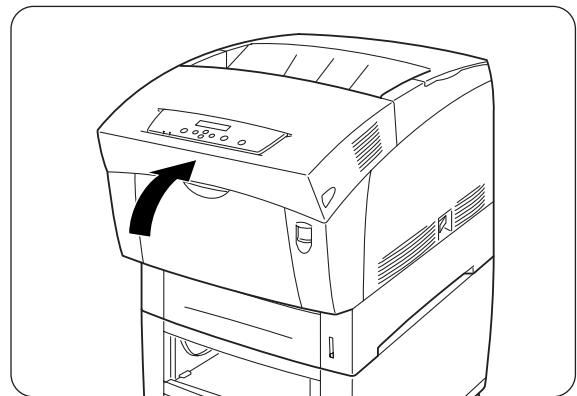

- 6.** Close all open paper trays.

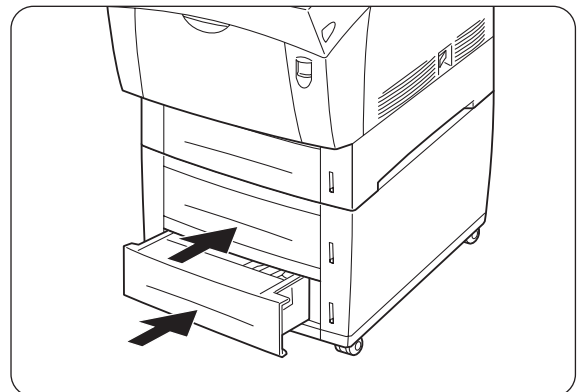

CHAPTER 8

ROUTINE MAINTENANCE AND CONSUMABLE REPLACEMENT

8.1 Replacing the Toner Cartridges

The printer uses four toner cartridges: black, yellow magenta, and cyan. When the toner supply in a cartridge begins to run out, the message 'Replace xxxx Toner (x)' message appears on the operation panel (xxxx is the toner cartridge color). Replace toner cartridge(s) as soon as the message prompting you to do so appears. The printer will stop operating if you do not replace the toner cartridge when required.

 **See**

Toner cartridges are consumables. For more information about consumables, refer to Appendix A "Introduction to Options and Consumables". For details about when to change consumables, refer to Appendix D "Life Span of Consumables".

8.1.1 Toner Cartridge Handling Precautions

 **WARNING**

Never throw a used toner cartridge into an fire. It can explode, causing injuries.

❖ Handling Precautions

- Never use a vacuum cleaner to clean toner. Static electricity could build up and damage sensors.
- Do not reuse toner cartridges once you have removed them from the printer. Loose toner could spill inside the printer and deteriorate print quality.
- To prevent residual toner from spilling, avoid shaking or bumping used toner cartridges.
- After moving a toner cartridge from a cold place to a warm place, allow 1 hour for the cartridge to adapt to room temperature before installing it. (This is not necessary if there is no condensation.)
- Toner should be still be washed off immediately if it gets on your hands or clothing.
- Only use toner cartridges recommended by Brother. Using toner cartridges that are not recommended may result in lower print quality and unsatisfactory printer performance.

❖ **Storage Precautions**

- Store cartridges away from direct sunlight under the following conditions:
- Ambient temperature range, 0 to 35°C. Humidity range 15 to 80% RH (no condensation). Avoid hot and humid areas.
- Avoid storing near magnetic objects such as CRT screens, disk drives, or floppy disks.
- Keep out of reach of children.

8.1.2 Replacing the Toner Cartridges

Follow the procedure below to replace toner cartridges.

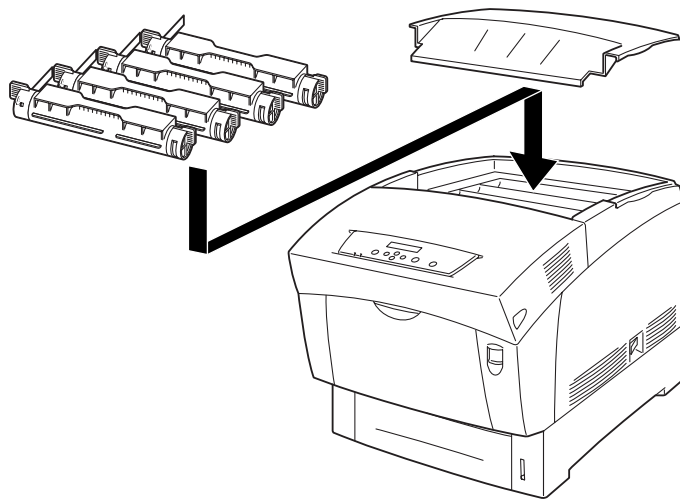

- 1.** Remove the top cover and place it on a flat surface.

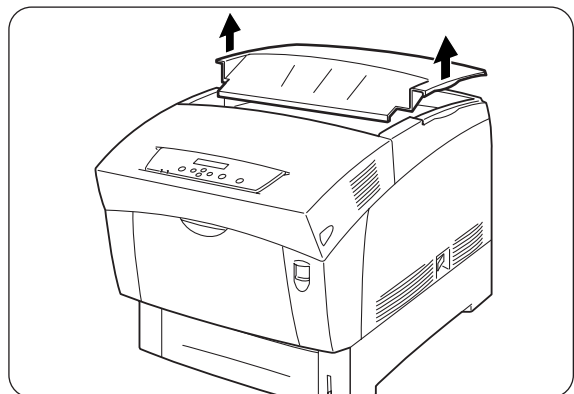

2. Grip the levers at the ends of the toner cartridge that you want to replace and pull them up.

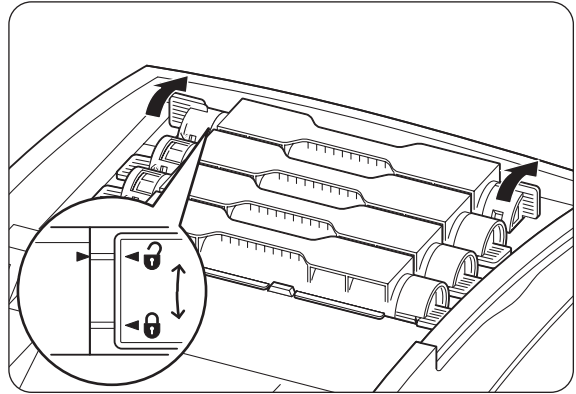

3. Pull out the toner cartridge.

⇒ **Note**

- Put the toner cartridge onto a piece of paper to prevent the toner from staining the floor or furniture.
- To prevent residual toner from spilling, avoid shaking or bumping used toner cartridges.

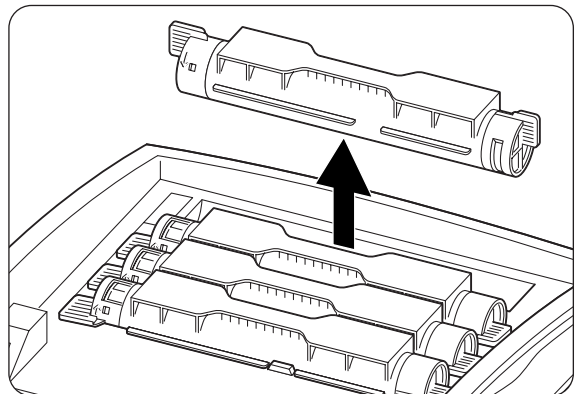

4. Select the new toner cartridge that is being replaced, and remove it from its packaging.

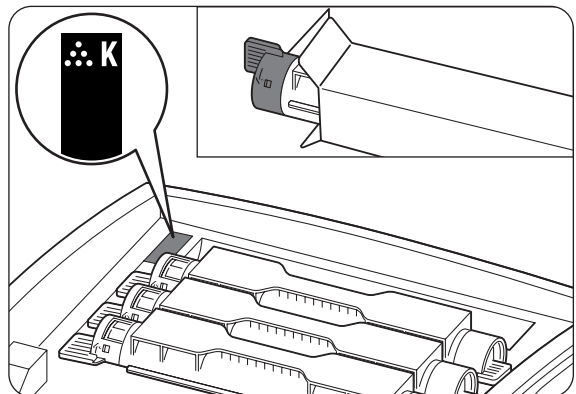

5. Shake the toner cartridge 7 or 8 times as illustrated to distribute toner evenly.

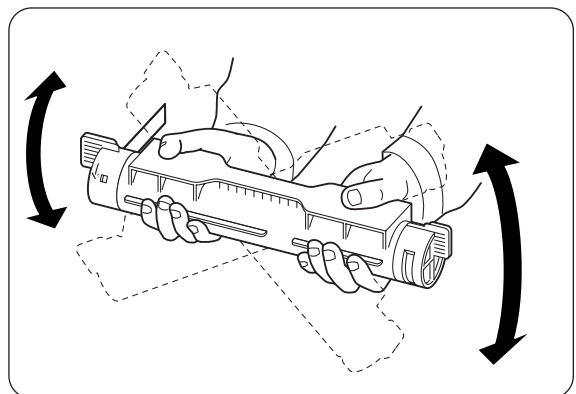

6. Align the toner cartridge with the corresponding insertion point in the printer and insert it as illustrated.

1. Toner seal

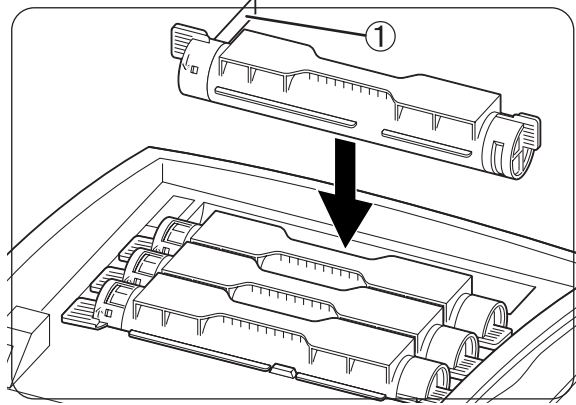

7. Grip the levers at each end of the toner cartridge with your fingers, then push down firmly to rotate the levers forward to the (⊕) position.

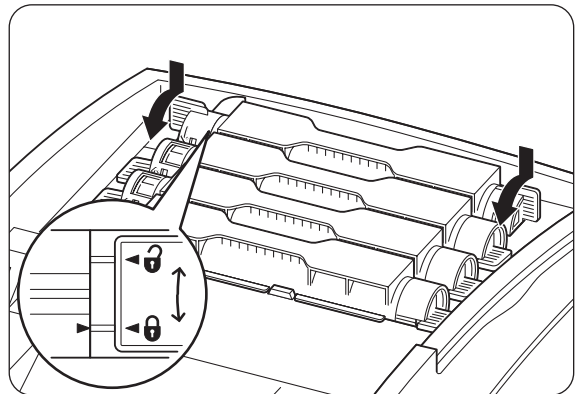

8. Pull the toner seal straight up to remove it.

 **Look**

Pull the toner seal straight up. Pulling the toner seal diagonally may tear the seal.

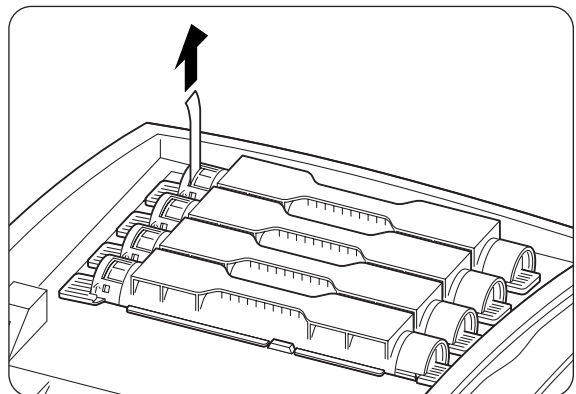

9. Replace the top cover.

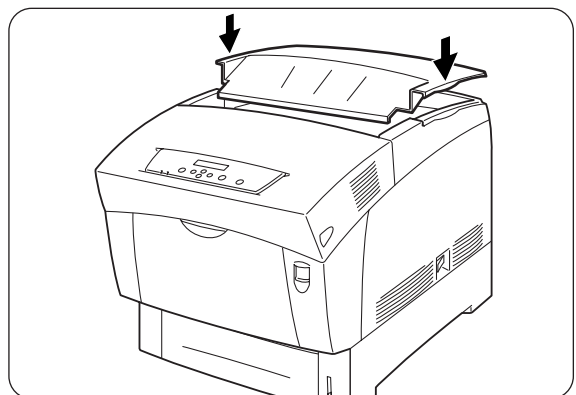

8.2 Replacing the Print Head Cartridge

This print head cartridge consists of the light-sensitive print head, the developer and the transfer roll.

When the print head deteriorates, 'Replace Print Head Cartridge' message appears on the operation panel.

Replace the print head cartridge as soon as the message prompting you to do so appears.

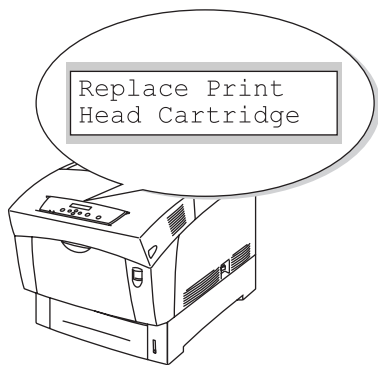

 **See**

The print head cartridge is a consumable. For more information about consumables, refer to A.1 "Introduction to Options and Consumables".

For details about when to change consumables, refer to A.4 "Life Span of Consumables".

8.2.1 Print Head Cartridge Handling Precautions

WARNING

Never throw a print head cartridge into an flame. It can explode, causing injuries.

Handling Precautions

- Make sure that nothing touches or scratches the light-sensitive print head surface (blue colored part) or transfer roll (black colored part). Scratches, dirt, or oil from your hands onto the print head or transfer roll will deteriorate print quality.
- Do not expose the print head cartridge to direct sunlight and avoid exposing the print head cartridge to fluorescent indoor light, as this may result in dropouts or dirty printing.

- When replacing the print head cartridge, work on a desk or other flat surface to avoid scratching the light-sensitive print head and transfer roll.
- Avoid removing the print head cartridge from the printer before it is time to replace it. Removing and replacing the print head cartridge can cause dirt to stick to the cartridge and deteriorate print quality.
- Avoid tilting or shaking the print head cartridge when removing it, as toner may spill inside the printer and cause damage.
- To ensure good print quality, keep the print head cartridge level when handling it.
- Only use print head cartridges recommended by Brother. Using a print head cartridge that is not recommended may result in lower print quality and unsatisfactory printer performance.

❖ **Storage Precautions**

- Do not unpack new print head cartridges until you are ready to install them. If a print head cartridge is unpacked, put it in its aluminum package for storage.
- Store print head cartridges away from direct sunlight under the following conditions:
- Ambient temperature range, 0 to 35°C. Humidity range 15 to 80% RH (no condensation). Avoid hot and humid areas.
- Avoid storing near magnetic objects such as CRT screens, disk drives, or floppy disks.
- Keep out of reach of children.
- Store in a level position.

8.2.2 Replacing the Print Head Cartridge

Follow the procedure below to replace the print head cartridge.

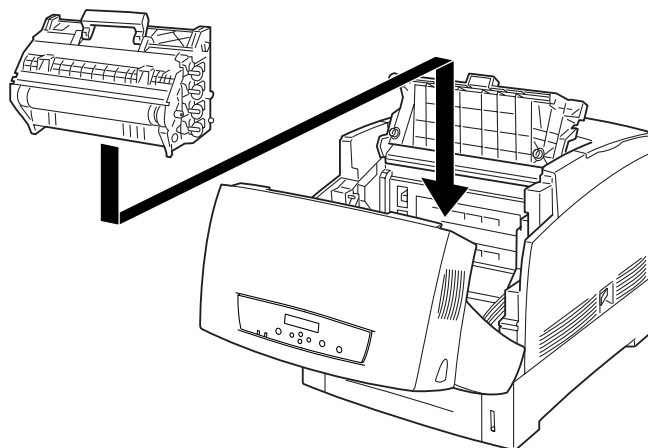

1. Push up button 'A' (1) and fully open the front cover (2).

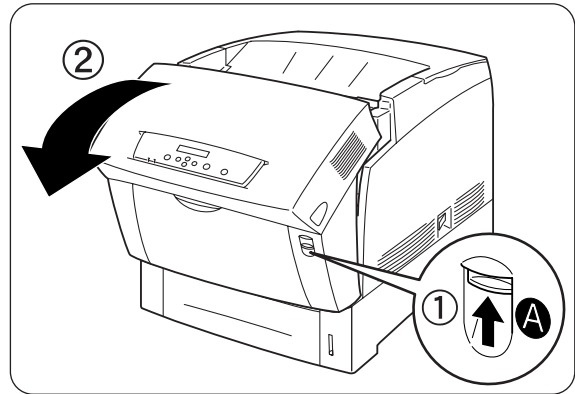

2. Push the button as shown and open the paper outlet cover.

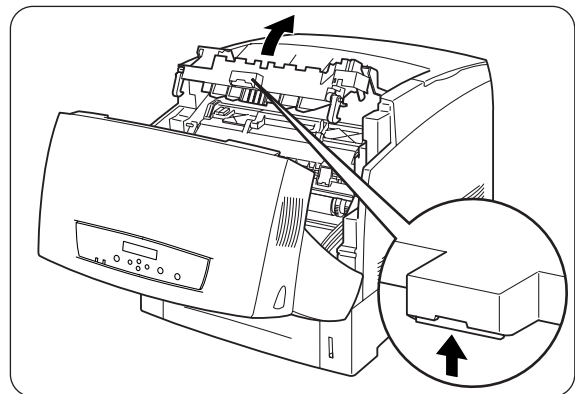

3. Grip the handle on top of the print head cartridge and gently lift it out of the printer.

Look

Hold the print head cartridge by its handle to prevent it from falling.

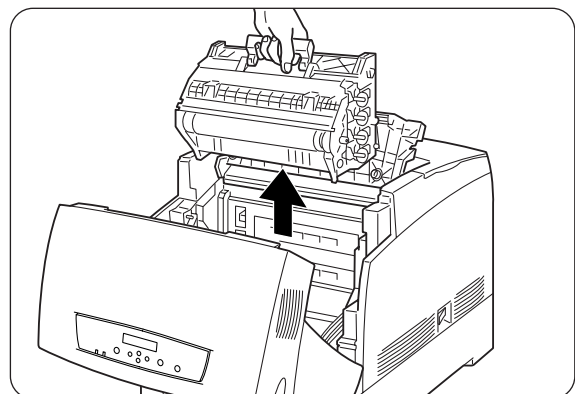

4. Open the top of the new print head cartridge box and pull off the top part of the aluminum package.

Note

Remove the sheet by working inward from the two notches.

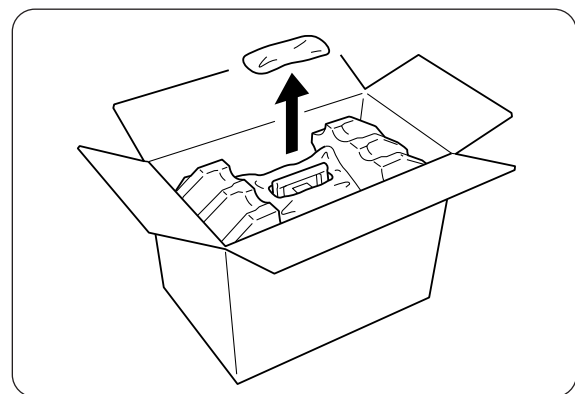

5. Grip the handle on top of the print head cartridge and gently lift it. Place the cartridge onto a flat surface.

Look

Lift the print head cartridge by the handle. Do not allow the cartridge to touch anything when removing it from the box.

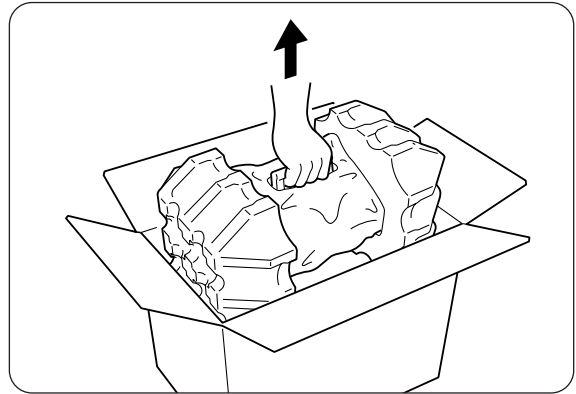

6. Remove the polystyrene packing and open the top of the aluminum package from the left and right.

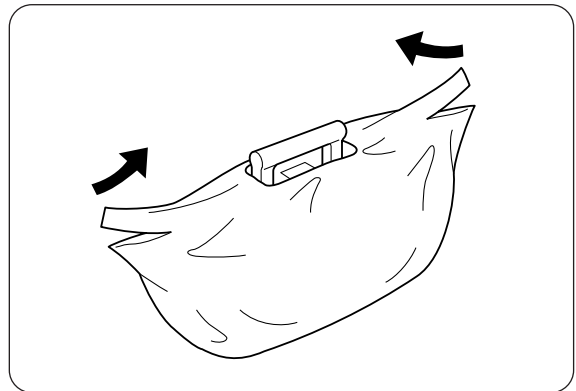

7. Take the new print head cartridge out of its package and pull hand on each of the 4 seals to remove them. Pull the seals straight out.

Note

Keep the print head cartridge polystyrene packing, aluminum package, and box in case you need to transport the printer over long distances in the future.

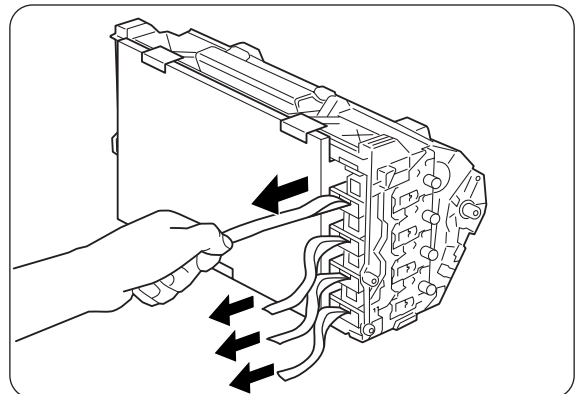

8. Remove the tape from the top of the cartridge (1), hold the protective cover on both sides and remove it from the print head cartridge (2).

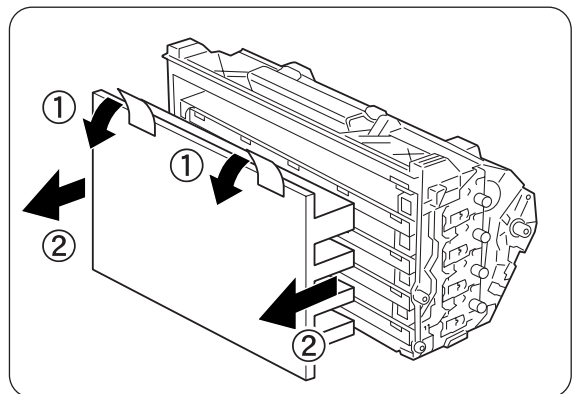

- 9.** Grip the handle on top of the print head cartridge and face the flat part towards the back of the printer.

1. Flat part facing to the rear

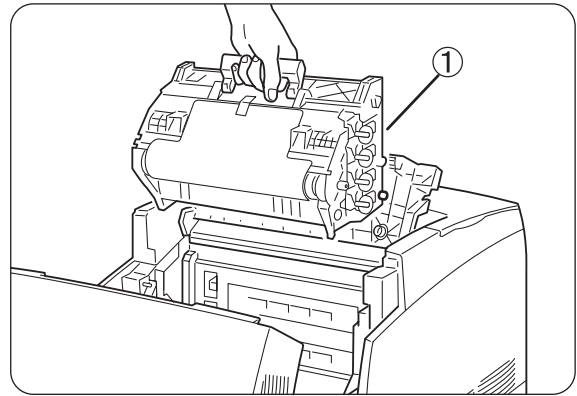

- 10.** With the flat part of the cartridge facing the rear, align the orange rollers on both sides of the print head cartridge with the slots in front of the arrows on the printer, and gently lower the cartridge into the printer.

1. Protective sheet
2. Orange rollers

 **Look**

- Lowering the cartridge into the printer without correctly aligning the roll with the slots can damage the cartridge.
- Do not allow the surface covered with a protective sheet to come into contact with anything.

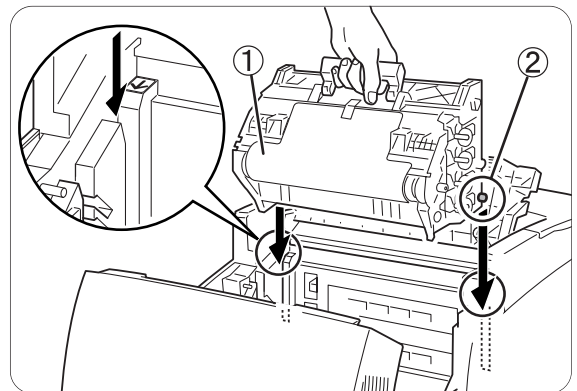

- 11.** Pull the protective sheet on the cartridge straight up to remove it, as illustrated.

1. Do not touch the transfer roll

 **Look**

Do not touch the transfer roll (black part). Make sure that nothing touches or scratches the roll surface. Scratches, dirt or oil from your hands onto the roll deteriorates print quality.

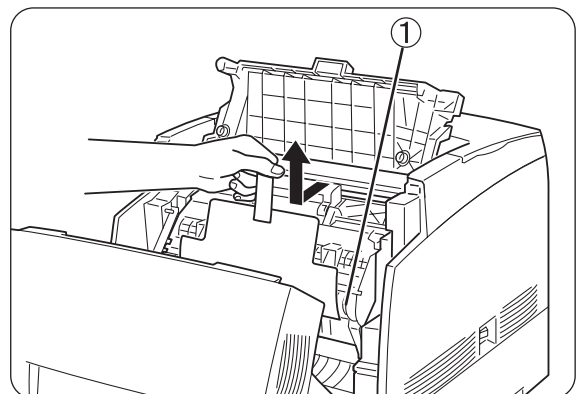

12. Close the paper outlet cover.

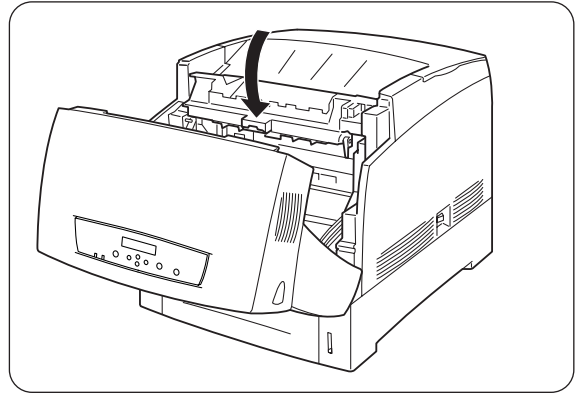

13. Close the front cover.

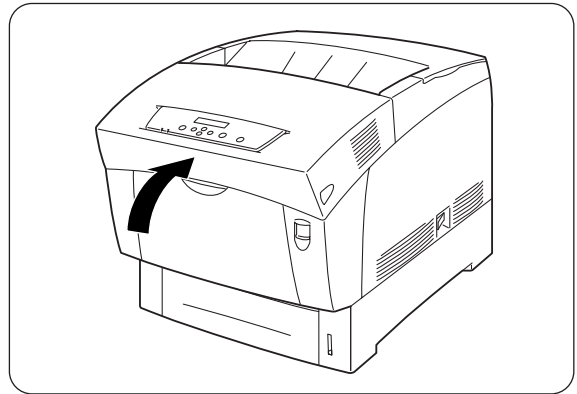

8.3 Replacing the Transfer Roll Cartridge

The transfer roll cartridge consists of a transfer roll and a waste toner collection box. When the transfer roll cartridge deteriorates, 'Replace Transfer Roll' message appears on the operation panel. Replace the transfer roll cartridge as soon as the message prompting you to do so appears. The printer will stop operating if you do not replace the cartridge when required.

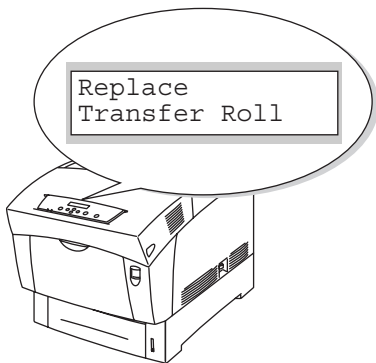

See

The transfer roll cartridge is a consumable. For more information about consumables, refer to A.1 "Introduction to Options and Consumables". For details about when to change consumables, refer to A.4 "Life Span of Consumables".

8.3.1 Transfer Roll Cartridge Handling Precautions

⚠ WARNING

Never throw a used transfer roll cartridge into fire. It can cause an explosion and injuries.

❖ Handling Precautions

- Replace the transfer roll cartridge as soon as the message prompting you to do so appears.
- The printer stops operating if you do not replace the cartridge when required.
- Do not attempt to reuse toner from the waste toner collection box.
- When you remove the transfer roll cartridge from the printer because the waste toner collection box is full, do not attempt to empty the waste toner box and reuse the cartridge, as toner may spill inside the printer and cause damage.
- Avoid removing the transfer roll cartridge from the printer before it is time to replace it. Toner may spill inside the printer, causing damage.

8.3.2 Replacing the Transfer Roll Cartridge

Follow the procedure below to replace the transfer roll cartridge.

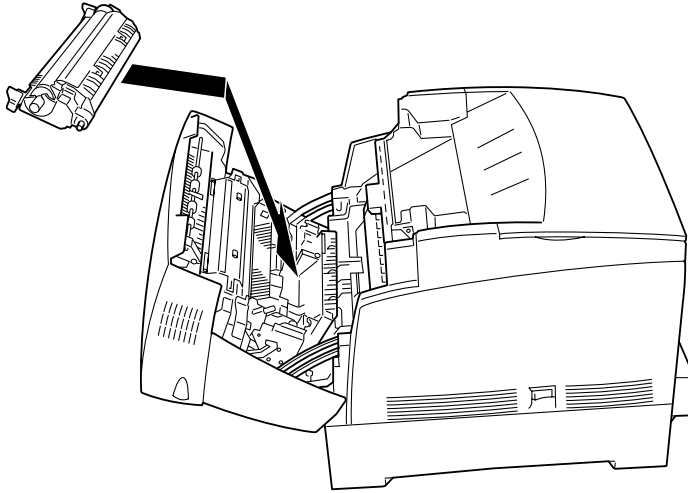

1. Push up button 'A' (1) and fully open the front cover (2).

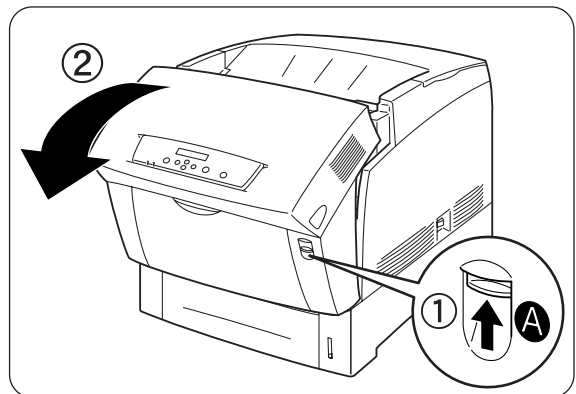

2. Grip the orange tabs at both ends of the transfer roll (1) and gently lift it out of the printer (2).

 **Look**

Lift the transfer roll carefully to prevent waste toner from spilling out.

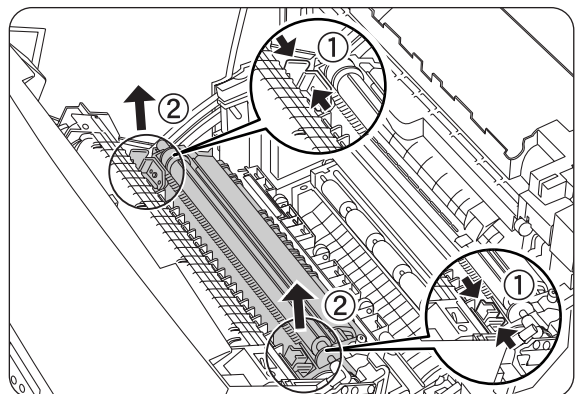

- 3.** Unpack a new transfer roll cartridge and grip the orange tabs as shown.

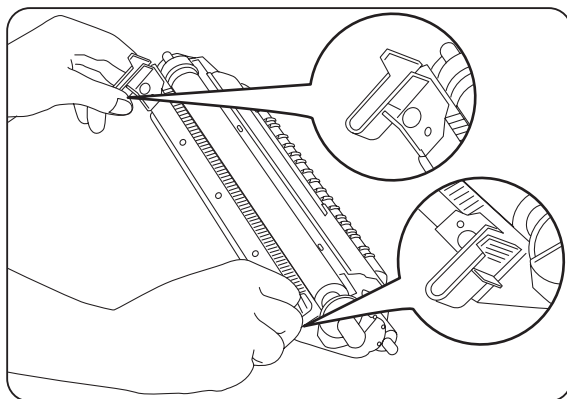

- 4.** Insert the pins at both ends of the transfer roll cartridge into the bearings inside the printer, and gently push the roll into the printer.

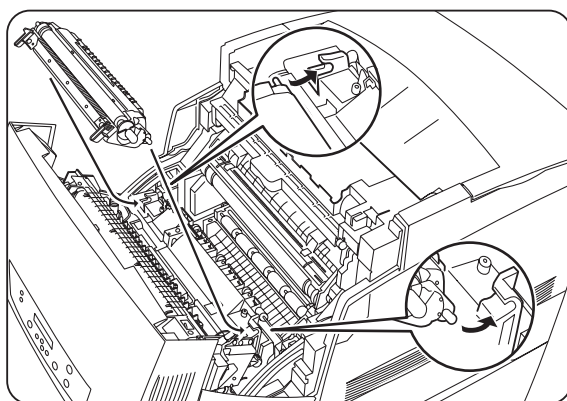

- 5.** To lock the transfer roll cartridge into the printer, push down on the tabs until you hear a click.

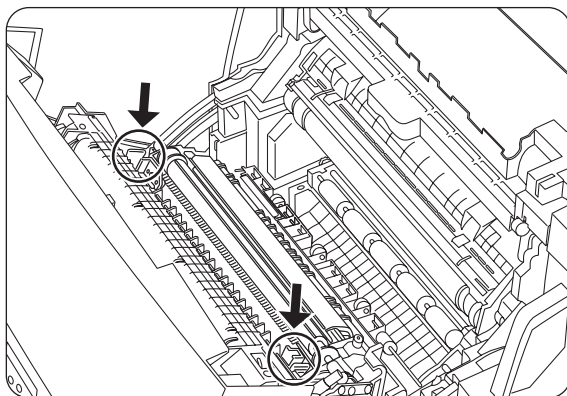

- 6.** Close the front cover.

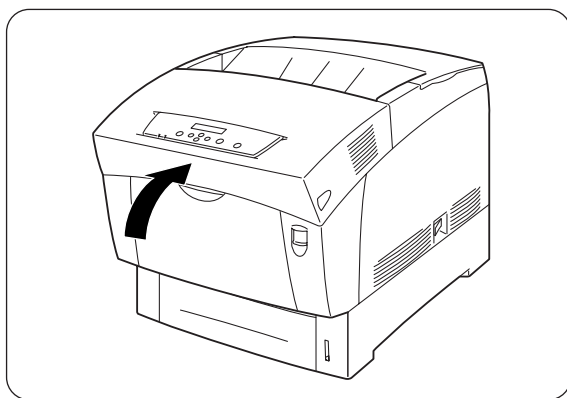

8.4 *Printing Reports and Lists*

Use the operation panel to print the following reports and lists.

- **Printer Configuration List**
Use this to confirm options installed in the printer and to check the network settings on the printer.

⇒ **Note**

8.4.1 “Confirming Printer Configuration and Network Settings”.

- **Panel Settings List**
Use this check the parameters set with the control panel.
- **PCL6 Font List**
Use this to find out which fonts are loaded into the printer.
- **Print Log**
This is a report of the last 22 print jobs received by the printer. Use it to check whether the jobs were printed normally or not.

⇒ **Note**

8.4.2 “Checking the Print Log”

8.4.1 Confirming Printer Configuration and Network Settings

Printing the printer configuration list allows you to check what options are installed on the printer and printer network settings.

This section describes how to print the printer configuration list.

⇒ **Note**

For details about control panel operations, refer to 5.2 “Basic Menu Operation”.

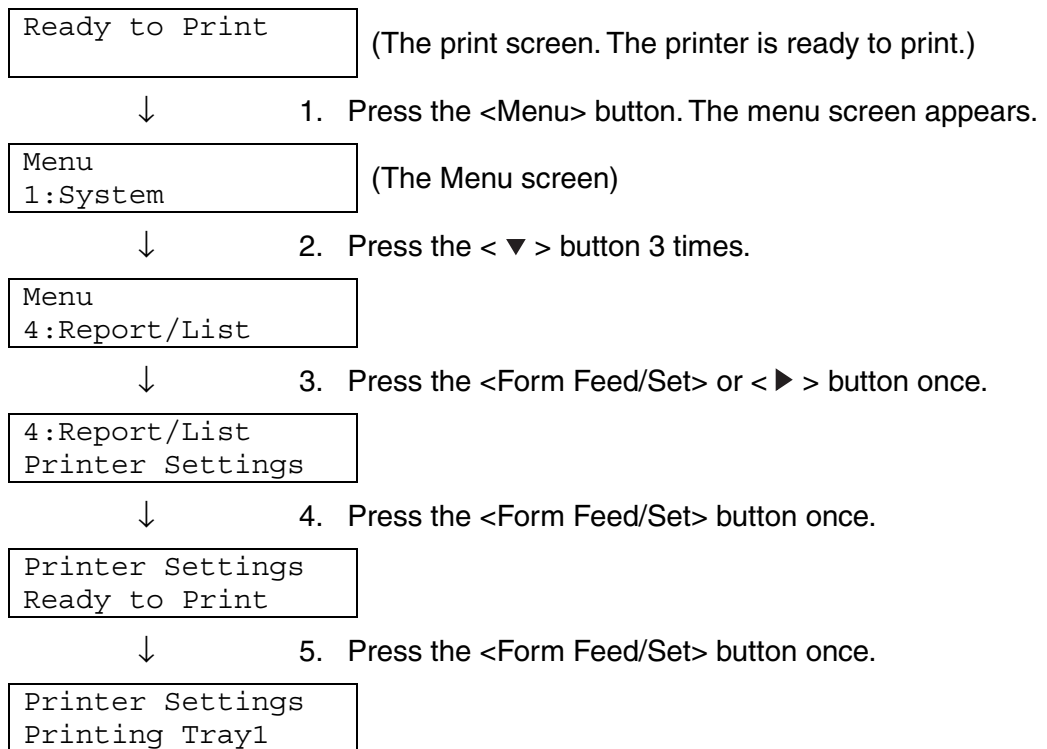

When printing is finished, the print screen reappears.

8.4.2 Checking the Print Log

Use the control panel to print the print log. The print log is a report of the last 22 print jobs received by the printer. Use it to check whether the jobs were printed normally or not.

⇒ Note

When 'Auto Log Print' in the '1 System' menu is set to 'ON', the print log is printed automatically every 22 print jobs (Default: 'OFF'). For more details, refer to 5.3 "List of Menu Items".

This section describes how to print the print log.

📖 See

For details about control panel operations, refer to 5.2 "Basic Menu Operation".

👉 Look

The print log is printed on A4 paper. Set the A4 paper lengthwise into the paper tray.

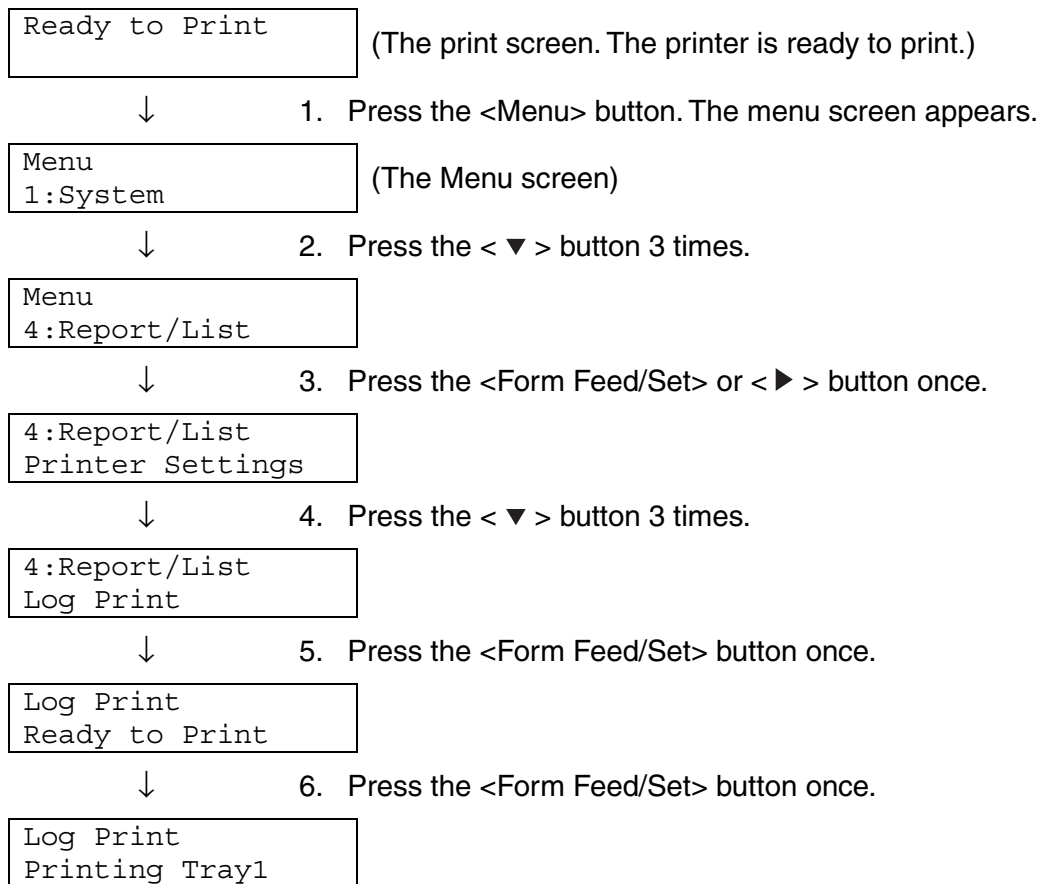

When printing is finished, the print screen reappears.

8.5 *Confirming Printer Status from Your Computer*

This printer features a variety of network tools that enable you to check the status of the printer from your computer through the network.

Using these tools saves you from having to leave your computer to check if the printer is working properly or not.

This section gives you a basic introduction of the network tools.

8.5.1 *Checking Status and Remaining Amounts of Consumables using a Web Browser*

When using TCP/IP to communicate with the printer, you can check the printer status and look at and change printer settings through the network from a Web browser.

1. Turn the computer on and start your Web browser.
2. In the Address box of your Web browser, type the IP address or the Internet address of the printer and press the enter key.
3. The Web Based Management screen appears.
4. Click 'Job Print Log'.
The Status information about jobs requested from the control panel as well as each protocol is displayed.

⇒ **Note**

Click 'View Job Print Log' in the tree on the left to view the print log of completed jobs.

5. Click the 'Status' tab.
Printer information appears on the screen.
Information about paper trays, the output tray, printer covers, remaining consumables and toner, and the number of sheets output appears in this area.
6. Click 'Fault Status'.
Event information appears on the screen.
Use this to check for errors. The control panel status of the printer is also displayed.

8.6 *Cleaning the Printer*

We recommend that you clean the printer at least once a month to keep it in good working condition and to maintain print quality.

⚠ CAUTION

Turn off the printer and disconnect the power cord from the AC outlet before cleaning the printer. Failure to turn off the printer and disconnect the power cord may result in electric shock.

❖ *Cleaning Precautions*

- Never spray anything directly onto the printer. Droplets can enter the printer and cause malfunctions. Never use detergents other than neutral detergents.
- Never lubricate the printer with oil. The printer does not require lubrication.
- Never use a vacuum cleaner to clean the printer.

❖ *Cleaning the outside of the printer*

1. On the printer's right side, press the side of the power switch marked [O] to turn off the printer.

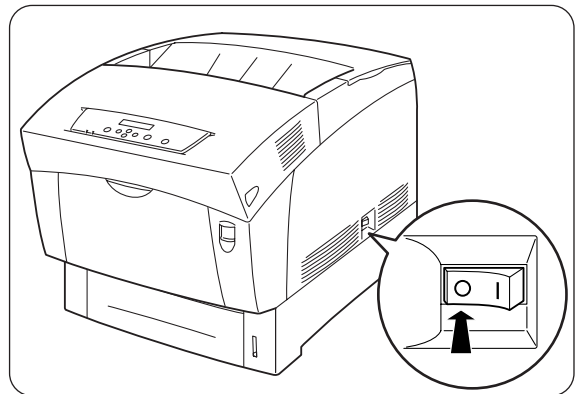

2. Use a soft, damp, well-squeezed cloth to clean the outside of the printer. If some stains prove difficult to remove, use a cloth lightly moistened with neutral detergent.

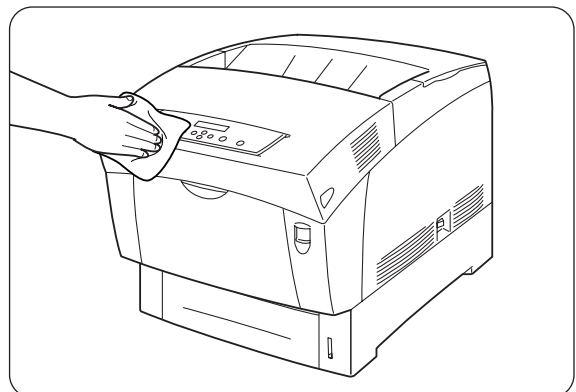

3. Wipe any remaining water with a soft, dry cloth.

8.7 Transporting the Printer

Before transporting the printer, follow the procedure below:

CAUTION

- To prevent injuries, this printer should be lifted by at least two people.
- To lift the printer, face the front of the printer and grip the recessed areas at the bottom left and right with both hands. Never try to lift the printer by gripping any other areas. Lifting the printer by gripping other areas can cause the printer to fall, resulting in injuries.
- When lifting the printer, get a firm footing and bend your knees to avoid possible injuries to your back.

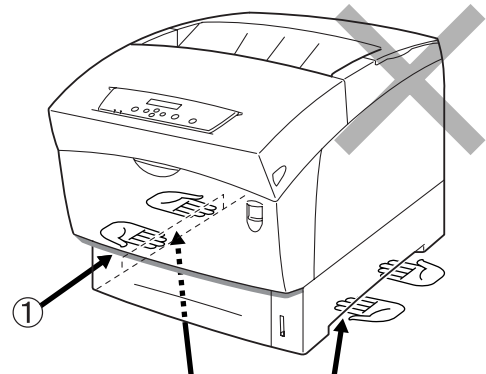
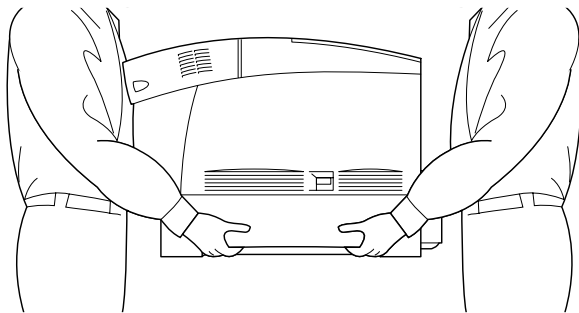

If you hold the printer by the front cover, left or right sides, there is a danger of the printer falling.

1. Recessed area

Look

- When carrying the printer, keep it level to prevent trays or consumables from falling out. Do not tilt it more than 10 degrees in any direction.
 - When moving the printer, keep the toner cartridges in the locked position and do not remove them from the printer. Toner may spill inside the printer and damage it.
 - When the optional 2 Tray Module is installed, remove it before transporting the printer. If the tray module is not removed, it may fall, resulting in damage or injuries. To remove the 2 Tray Module, refer to the literature provided with the tray module.
-

1. On the printer's right side, press the side of the power switch marked [O] to turn off the printer.

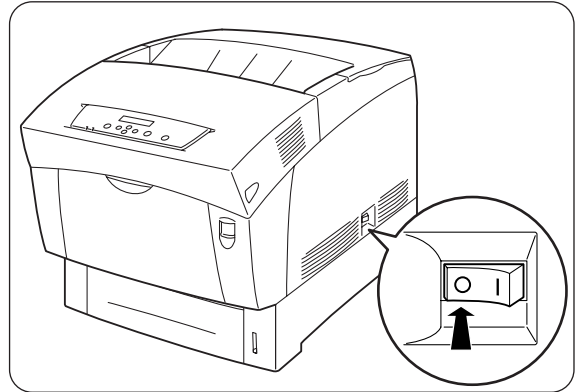

2. Disconnect the power cord, interface cable, and any other cables.

⚠ WARNING

Never touch a power cord with wet hands. This constitutes an electric shock hazard.

⚠ CAUTION

When unplugging the printer, grasp the plug instead of the power cord. Forcibly pulling the power cord can damage it and cause fire or electric shocks.

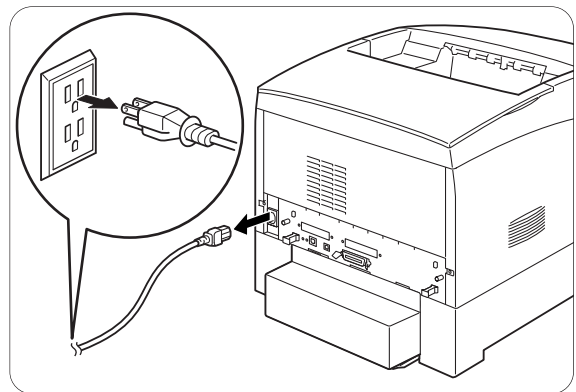

3. Gently pull out the paper tray until it stops.

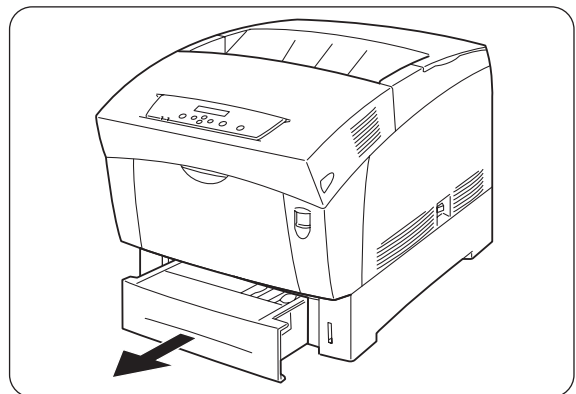

4. Hold the tray with both hands, lift the front slightly and pull it completely out of the printer.

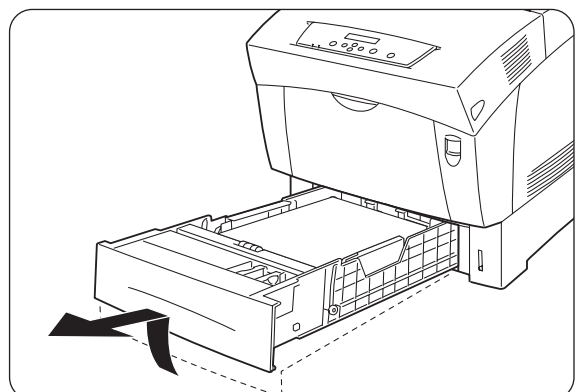

5. Remove the paper from the paper tray, and store it in a dry, dust-free place.

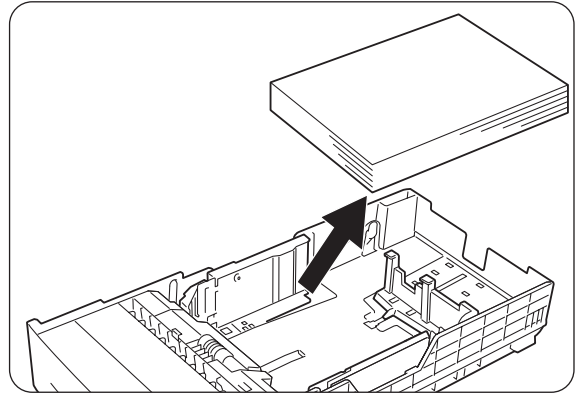

6. Insert the cardboard spacers in the tray as illustrated.

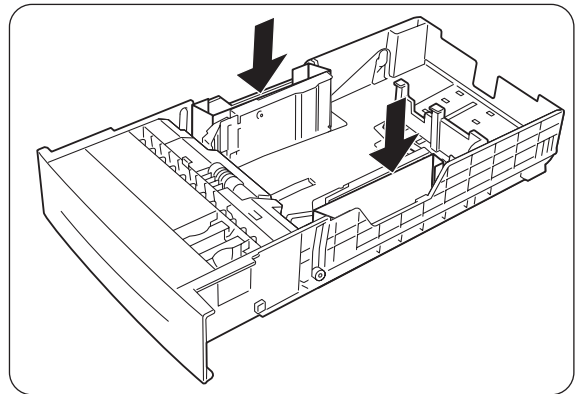

7. Hold the paper tray with both hands, align it with the opening in the printer and gently insert it.

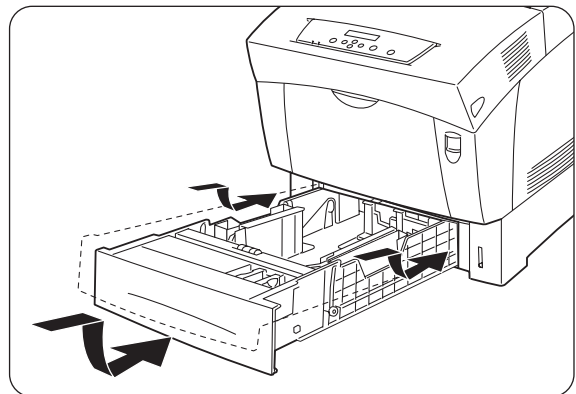

8. Push the paper tray completely back into the printer.

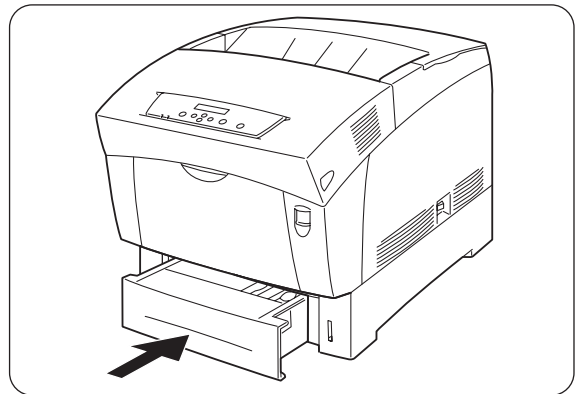

- 9.** Remove the tray cover from the rear of the printer.

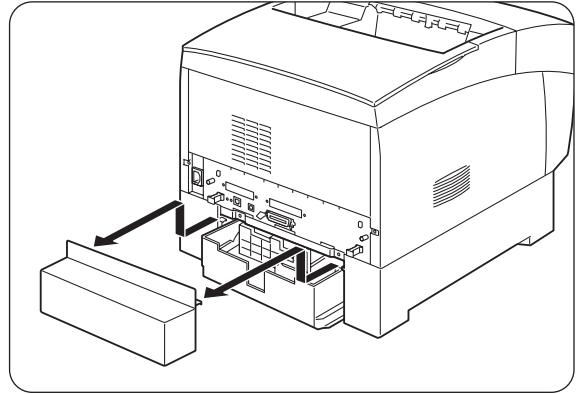

- 10.** Push up button 'A' (1) and fully open the front cover (2).

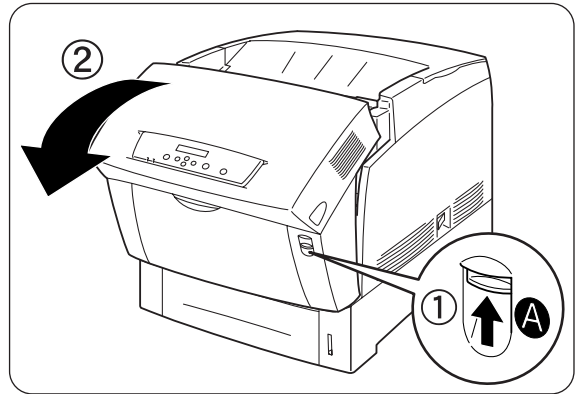

- 11.** Push the button as shown and open the paper outlet cover.

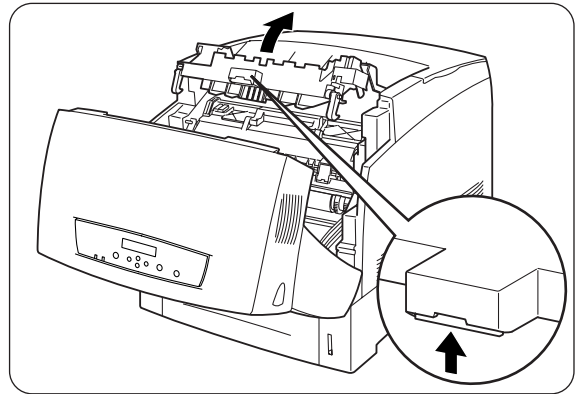

- 12.** Grip the handle on top of the print head cartridge and gently lift it out of the printer.

1. Transfer roll

Look

- Do not touch the transfer roll.
- Hold the print head cartridge by its handle to prevent the cartridge from falling.

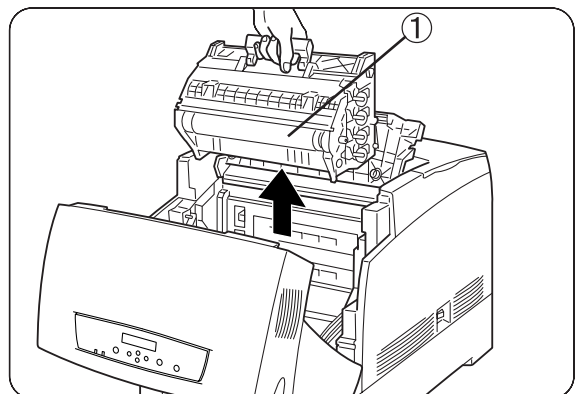

⇒ **Note**

Wrap the print head cartridge in its aluminum package or thick paper to avoid exposing it to direct sunlight or other strong light.

- 13.** Close the paper outlet cover.

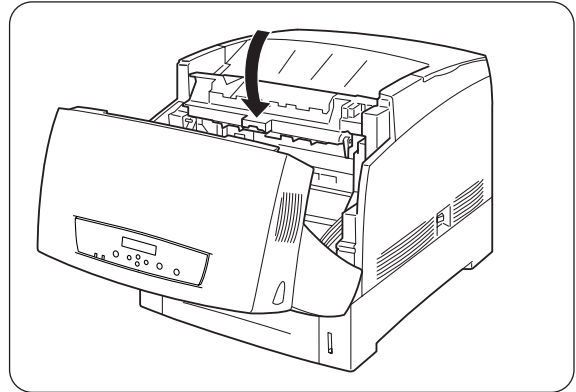

- 14.** Close the front cover.

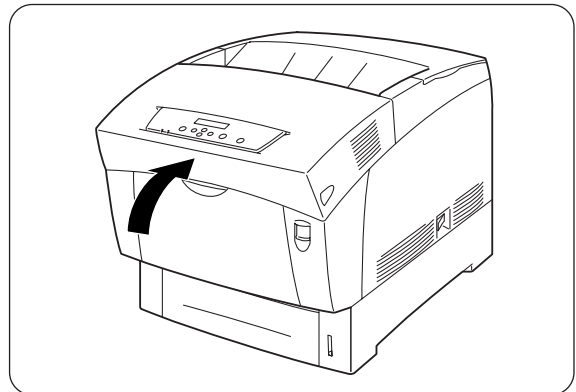

- 15.** To protect the printer from damage, pack it in a box before transporting it.

☞ **Look**

After moving the printer to the new location, you need to readjust the color registration. For details about this operation, refer to 1.1 “Adjusting Color Registration”.

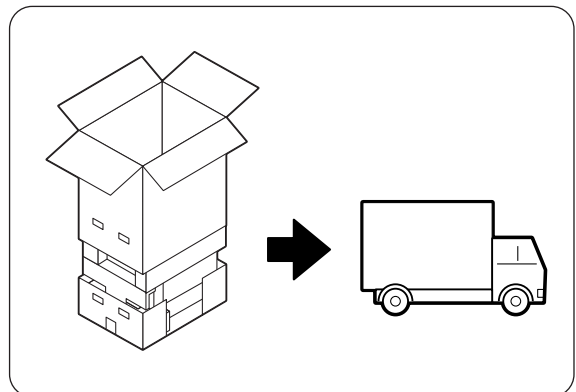

8.8 Storing the Printer

Follow the procedure below when you do not need to use the printer for a long period.

1. On the printer's right side, press the side of the power switch marked [O] to turn off the printer.

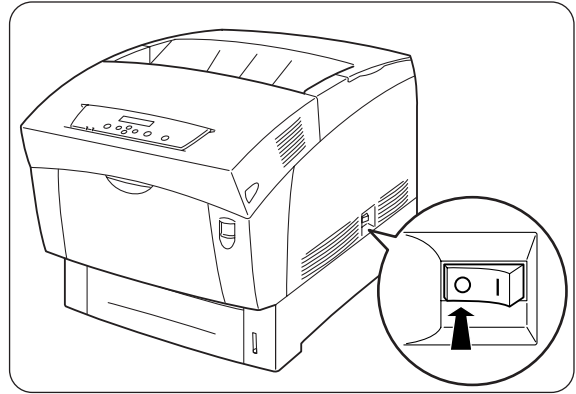

2. Disconnect the power cord, interface cable, and any other cables.

⚠ WARNING

Never touch a power cord with wet hands. This constitutes an electric shock hazard.

⚠ CAUTION

When unplugging the printer, grasp the plug instead of the power cord. Forcibly pulling the power cord can damage it and cause fire or electric shocks.

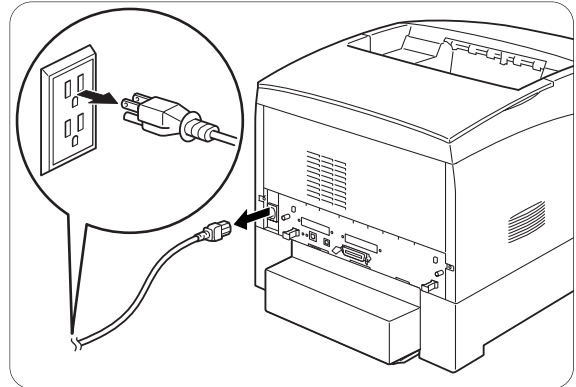

3. Remove the paper from the paper tray, and store it in a dry, dust-free place.

👉 Look

If the paper proves difficult to remove, pull the tray completely out of the printer and try removing the paper again.

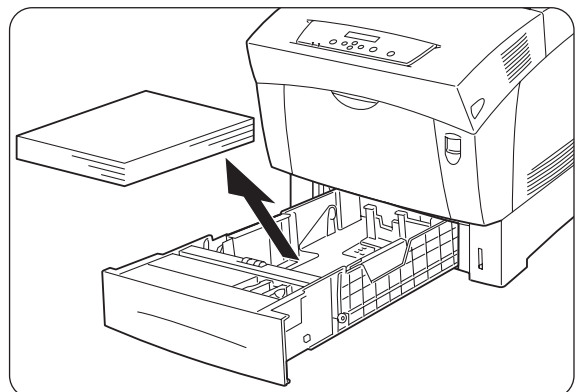

APPENDIXES

A.1 Introduction to the Optional and Consumable Items

The following options are available for this printer. To order any of these options, contact your dealer.

A.1.1 Options

❖ **Hard Disk**

The optional hard disk enables high-speed sorting, when you print multiple copies of a document.

For the installation procedure, refer to the documentation accompanying the hard disk.

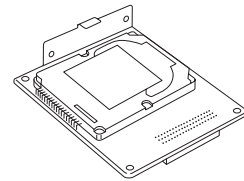

❖ **2 Tray Module**

This option allows you to attach an additional 2 trays to the printer. Each tray of the module holds up to 500 sheets of paper. When installed, the trays become the printer's tray 2 and tray 3.

To install the tray module, refer to the documentation accompanying the tray module.

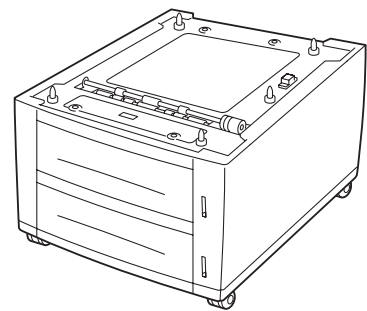

❖ **Memory Expansion Card**

If you want to print color documents containing complex graphic layouts or large amount of color image data, it may be necessary to expand the memory of your printer.

For the installation procedure, refer to A.5 "Adding the Expansion Memory".

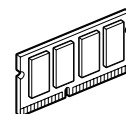

A.1.2 Consumable Items

❖ Toner Cartridges

The printer uses four toner cartridges: black, yellow magenta, and cyan.
For the installation procedure, refer to 8.1.2 “Replacing Toner Cartridges”.

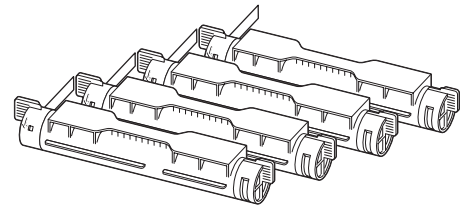

❖ Print Head Cartridge

Consists of the light-sensitive drum, the developer and the transfer roll.
For the installation procedure, refer to 8.2.2 “Replacing the Print Head Cartridge”.

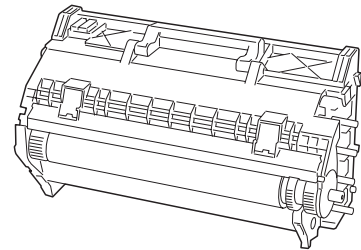

❖ Transfer Roll Cartridge

The transfer roll cartridge consists of a transfer roll and a waste toner collection box.
For the installation procedure, refer to 8.3.2 “Replacing the Transfer Roll Cartridge”.

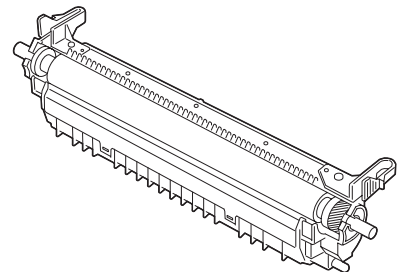

A.2 Getting Product Support Information

Access our user support web site for the latest drivers and information about your printer.

URL: <http://solutions.brother.com>

A.3 General Specifications

A.3.1 Printer Specifications

Type		Desktop Printer		
Print Method		Electro photographic		
Resolution		1,200 dots/25.4 mm (1,200 dpi), 600 dots/25.4 mm (600 dpi)		
Color Graduation		256 per color (16,700,000 colors)		
(*) Plain paper	1,200 dpi monochrome/color	Plain paper	Single-sided printing	8.0 sheets/minute
			Duplex Printing	5.0 surfaces/minute
		Specialty Paper (cardboard, transparency sheets, labels)	Single-sided printing	8.0 sheets/minute
			Duplex Printing	-
	600 dpi monochrome/color	Plain paper	Single-sided printing	16.0 sheets/minute
			Duplex Printing	10.0 surfaces/minute
		Specialty Paper (cardboard, transparency sheets, labels)	Single-sided printing	8.0 sheets/minute
			Duplex Printing	-
Paper Sizes		A5, B5 (JIS), A4, 8.5" × 11" (Letter), 8.5" × 14" (Legal), Executive, custom (width: 90-216 mm (3.5-8.5 in.), length: 139.7-900.0 mm (5.5-35.4 in.))		
Paper Type	Paper Tray	Plain paper 1 (60-75 g/m ²), plain paper 2 (76-99 g/m ²)		
	Multi -purpose Tray	Plain paper/cardboard (60-216 g/m ² (16.0-57.5 lb)), transparency sheets, envelopes, labels sheets, coated paper		
Paper Tray Capacity (Standard Domestic Paper)	Paper Tray	Standard: (Tray 1) 500 sheets * Option: 2 Tray Module (trays 2, 3) 500 sheets* × 2 (*) 350 A5 sheets		
	Multi -purpose Tray	100 sheets		
Output Capacity	Face Down Tray	250 sheets (All sheets suitable for use with the printer.)		
Memory Capacity (*3)		Standard: 64 MB (expandable to 320 MB) Option: 64, 128, or 256 MB (1 memory expansion slot available)		

Fonts (*2)	European (80 fonts)	<p>Albertus Medium/ Albertus Extra Bold Antique Olive/ Antique Olive It/Antique Olive Bd Arial/ Arial It/ Arial Bd/ Arial Bd It Clarendon Condensed Coronet Courier/ Courier It/ Courier Bd/ Courier Bd It Garamond Antiqua/ Garamond Kursiv/ Garamond Halbfett/ Gatamond Kurs Halb Letter Gothic/ Letter Gothic It/ Letter Gothic Bd Marigold CG Omega/ CG Omega It/ CG Omega Bd/ CG Omega Bd It CG Times/ CG Times It/ CG Times Bd/ CG Times Bd It Times New Roman/ Times New Roman It/ Times New Roman Bd/ Times New Roman Bd It Univers Md/ Univers Md It/ Univers Bd/ Univers Bd It Univers Condensed Md/ Univers Condensed Md It/ Univers Condensed Bd/ Univers Condensed Bd It AvantGarde Bk/ AvantGarde Bk Obl/ AvantGarde Demi/ AvantGarde Demi Obl Bookman Light/ Bookman Light It/ Bookman Demi/ Bookman Demi It CourierPS/ CourierPS Obl/ CourierPS Bd/ CourierPS Bd Obl Helvetica/ Helvetica Obl/ Helvetica Bd/ Helvetica Bd Obl Helvetica-Narrow/ Helvetica-Narrow Obl/ Helvetica-Narrow Bd/ Helvetica-Narrow Bd Obl New Century Schlbk Rm/ New Century Schlbk It/ New Century Schlbk Bd/ New Century Schlbk Bd It Palatino/ Palatino It/ Palatino Bd/ Palatino Bd It Times Rm/ Times It/ Times Bd/ Times Bd It Zapf Chancery/ Zapf Dingbats Symbol/ SymbolPS Wingdings</p>
PDL (Emulation)		PCL6, PostScript 3
Operating Systems Supported by the Printer Driver		<p>Windows® 95, Windows® 98, Windows® Me, Windows® NT 4.0, Windows® 2000/XP, Mac OS 8.1 to Mac OS X (USB connection supported by Windows 98 Second Edition*, Windows Me*, Windows 2000/XP*, Mac OS 8.6 to OS X However, we cannot guarantee the normal operation of all USB compatible equipment.</p>
Interface		<p>Bi-directional parallel (IEEE1284 compliant) USB 1.1 Ethernet 100Base-TX/10Base-T</p>
Noise Level		<p>Standby: 35 dB (A) or less, Operating (single-sided printing): 52 dB (A) or less, Operating (Duplex printing): 53 dB (A) or less.</p>
Power Supply		<p>100-127 VAC ± 10% (90V-140V), 50 ± 3 Hz/60 ± 3 Hz 220-240 VAC ± 10% (198V-264V), 50 ± 3 Hz/60 ± 3 Hz</p>
Power Consumption		Operating: 850 W, Standby: 45 W

Weight/Dimensions	Dimensions: 439 (W) × 638 (D)* × 445 (H) mm (17.3 (W) x 25.1 (D)* x 17.5 (H) in.) Weight: 35.3 kg (77.8 lb) (*) With the paper tray installed and the multi-purpose tray folded closed.
-------------------	--

- (*1)
 - Indicates the maximum speeds for the A4 and Letter sizes fed lengthwise (portrait).
 - During long print runs, printing may be cancelled in order to allow the printer to clean the interior of the developing unit. During cleaning, “Please Wait...” is displayed on the operation panel.

- (*2) The typefaces and Universal Font Scaling Technology™ (UFST™) are trademarks or registered trademarks of Agfa Monotype Corporation or the respective holders.

- (*3) We recommend that you expand memory up to 128 MB when you use print at 1200 dpi.

A.3.2 Network Specifications

❖ Common Specifications

Supported Standards	Ethernet Ver.2.0 IEEE 802.3
Network Protocols	TCP/IP, NetBIOS, IPX/SPX (NetWare), AppleTalk
Interface	100BASE-TX, 10BASE-T

❖ TCP/IP Specifications

Supported Operating Systems	Windows 95, Windows 98, Windows Me, Windows NT 4.0, Windows 2000/XP
Frame Type	Ethernet_II (Ethernet II)
Print Protocols	LPD (LPR), Port 9100 (Available in Windows 95, Windows 98, Windows Me, and Windows 2000/XP), IPP (Available in Windows Me and Windows 2000/XP)
Management Protocols	http, SNMP

❖ NetBIOS Specifications

Supported Operating Systems	Windows 95, Windows 98, Windows Me, Windows NT 4.0, Windows 2000/XP
Print Protocols	NetBIOS (TCP/IP), NetBIOS (NetBEUI)

❖ NetWare Specifications

Network Operating Systems	NetWare 3.X/4.X/5
Frame Type	Ethernet_II (Ethernet II), Ethernet_802.3 (IEEE 802.3), Ethernet_802.2 (IEEE 802.2), Ethernet SNAP (IEEE 802.1 SNAP)
Print Protocols	Print server mode Remote server mode
Management Protocols	SNMP

❖ AppleTalk Specifications

Supported Operating Systems	Mac OS 8.1-X
Frame Type	Ethernet SNAP (IEEE 802.1 SNAP)
Printer Type	PCL6

A.3.3 Printable Area

When using A4, 8.5" x 14" (Legal) or smaller.

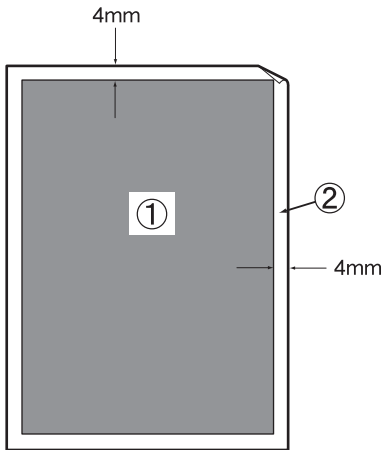

- “Printable area” refers to the area on a page where printing is possible.
- “Non-printable area” refers to the area (the edges) on the page where printing is not possible.

1. Printable area
2. Non printable area

A.4 Life Span of Consumable Items

❖ Life span of consumables (in printable pages)

Consumable	Number of printable pages^(*)
Black toner cartridge	About 8,500 pages
Yellow toner cartridge	About 6,000pages
Magenta toner cartridge	About 6,000 pages
Cyan toner cartridge	About 6,000 pages
Print Head Cartridge	About 30,000 pages
Transfer roll cartridge (includes waste toner collection box)	About 25,000 pages

(*) The number of printable pages corresponds to the printing conditions in the table below. The actual number of printable pages depends on the content of printed material, the paper size, and the operating environment. Differences in number of sheets printed may occur due to power on/off initialization and print quality maintenance operation.

Paper Size	A4 portrait
Coverage	5%
Monochrome/color ratio	1:1
Average number of sheets in a single print run	4

A.5 Adding the Expansion Memory

1. Turn off the printer, and then unplug the power cord from the AC outlet.

⚠ CAUTION

Before installing the optional accessories, turn off the printer and remove the power plug from the outlet. Installing optional accessories without turning off the printer could result in electric shock.

2. Loosen the two screws on the interface board located at the back of the printer.

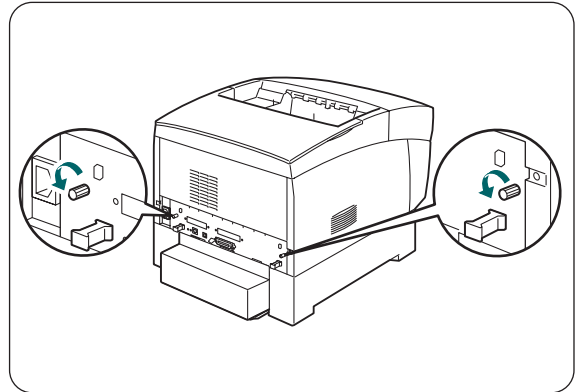

3. Hold the 2 handles on the interface board and slowly pull it towards you, then lay it on a desk or table.
4. Hold the expansion memory module by the edges and align the notches in the module with the protrusions in the slot.
5. Insert the module diagonally (1), then tilt it toward the interface board until it clicks into place (2).

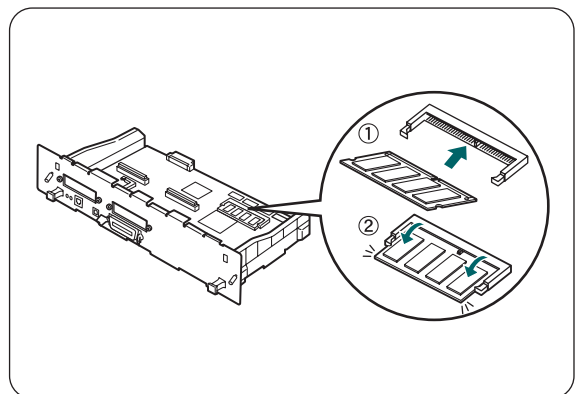

⇒ Note

To remove the memory module, open the retaining clips on both sides of the module by pushing them outward, grasp both edges of the module and pull it out straight.

INDEX

2	I
2 Tray Module.....7-11, A-1	ID Print.....5-9
A	Init NVM5-10, 5-16
Alarm indicator5-2	IP Address5-13, 5-14
Alarm Indicator6-22	IP Filter5-16
Alarm lamp6-3	IPX Frame Type.....5-14
Auto Log Print5-9	J
Automatic Duplex Printing4-5	Job Timeout5-9
B	L
Basis Weight.....5-11	LED5-2
Button A3-1	M
Button B3-1	Macintosh6-6
Buttons5-4	Menu button5-4
C	Menu screen5-3
Cancel Printing3-13	Multi-purpose Tray3-1, 4-19, 7-3
ColorRegiCorrect5-11	N
ConsumablesA-2	Network6-15
Control panel.....3-1	O
Cover Open indicator5-2	Options3-16, A-1
D	P
Density Sensor6-24	Panel Language5-9
E	Panel Settings.....5-12
ECP mode5-12	Paper jams6-13
Error Alarm5-8	Paper Meter3-1
Error Message.....6-17	Paper Stopper3-1
Ethernet5-13	Paper Tray3-1, 4-8, 7-4
Ethernet Interface Connector.....3-2	Parallel Interface Connector3-2
Exhaust Grille3-1, 3-2	PCL6 Font List.....5-12
F	Power6-2
Face Down Tray.....3-1	Power Cord Connector3-2
Faded printouts.....6-8	Power Save Time5-7
Front Cover3-1	Power Switch3-1
Fuser Cartridge3-3	Print Head Cartridge3-3, 8-5, A-2
G	Print Quality6-7
Gateway Address5-14	Printer Driver2-1, 2-3
H	Printer Settings.....5-12
Hard DiskA-1	Protocol1-9
Help3-10	R
	Ready indicator5-2
	Ready lamp6-3

S

Security	5-11
Subnet Mask	5-14
Suitable Paper Types	4-1

T

TCP/IP	5-13
Text Print.....	5-10
Toner Cartridges	3-2, 8-1, A-2
Top Cover	3-2
Transfer roll cartridge.....	3-3
Transfer Roll Cartridge.....	8-11, A-2
Transparency Sheets	3-22

U

Unsuitable Paper Types	4-6
USB Interface Connector	3-2

V

Ventilation Intake Grille.....	3-1, 3-2
--------------------------------	----------

W

Web Based Management	8-18
Windows	6-5